

6 5 4 3 2 1

| REVISION | | | | | |
|----------|-----|-----------------|------------|------------|----------|
| ZONE | REV | DESCRIPTION | DATE | CHANGED BY | APPROVED |
| | A | INITIAL RELEASE | 08/07/2023 | LNAGARAJ | EKIM |

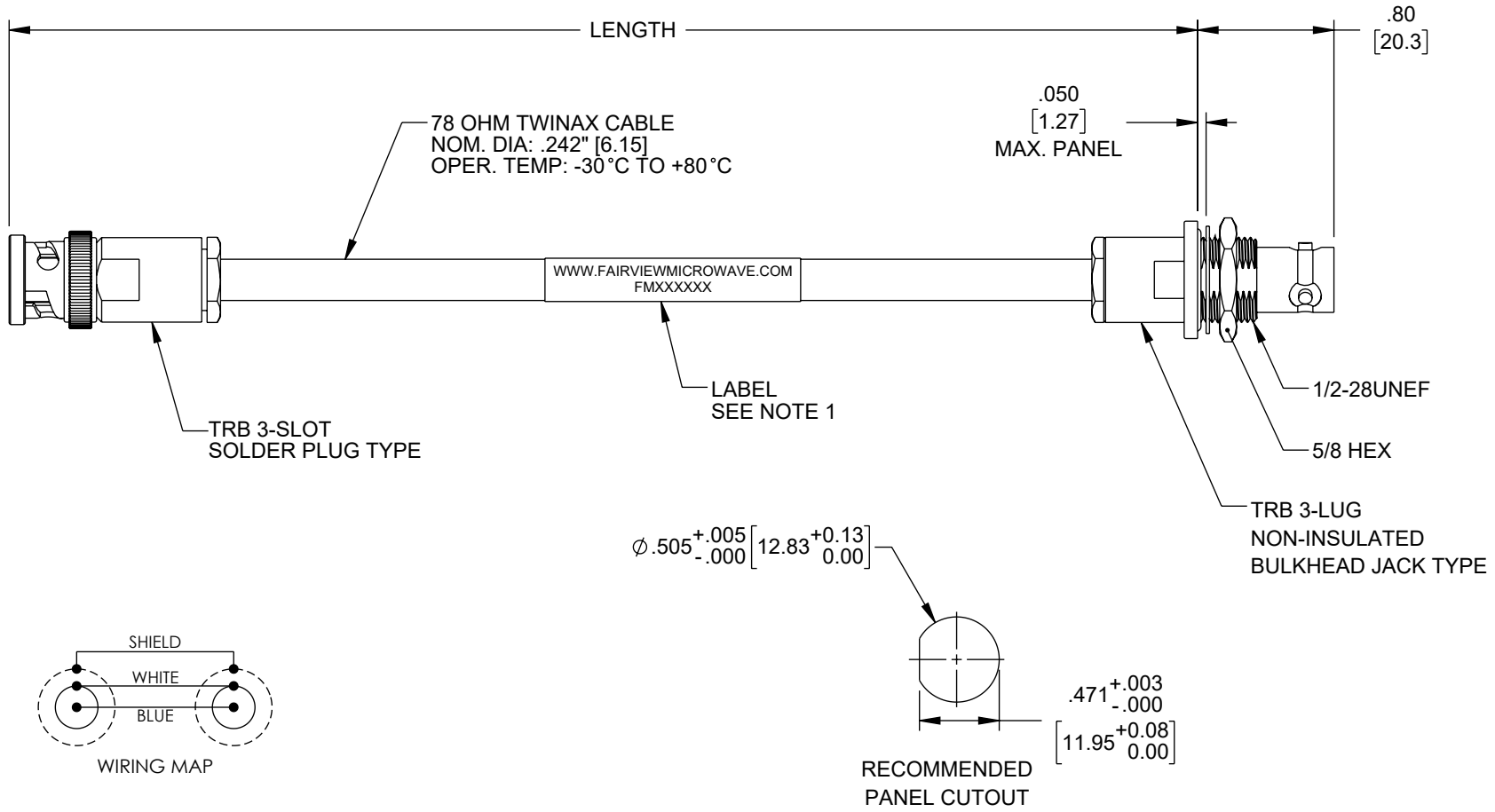

NOTES:

1. CABLE ASSEMBLY LENGTH LABEL PLACEMENT: 36 INCHES OR LESS, ONE LABEL APPROXIMATELY CENTERED. LONGER THAN 36 INCHES, TWO LABELS APPROXIMATELY 6 INCHES FROM EACH CONNECTOR.
2. CABLE ASSEMBLIES SHALL BE TESTED FOR CONTINUITY.
3. CABLE ASSEMBLY LENGTH DETERMINED BY PN AS ILLUSTRATED: FM3MSA00578-XX (XX = OAL IN METERS).

UNLESS OTHERWISE SPECIFIED LEADING DIMENSIONS ARE INCHES DIMENSIONS IN [] ARE MILLIMETERS

| TOLERANCES: | |
|---------------------|------------------|
| .X = ±.2 [5] | FRACTIONS ± 1/32 |
| .XX = ±.02 [0.5] | ANGLES ± 1° |
| .XXX = ±.005 [0.13] | |

CABLE LENGTH TOLERANCES:

| | | |
|-------------|-------------|-----------------|
| >12 [305] | ≤60 [1524] | = +1 [25] / -0 |
| >60 [1524] | ≤120 [3048] | = +2 [51] / -0 |
| >120 [3048] | ≤300 [7620] | = +6 [152] / -0 |
| >300 [7620] | | = +5% / -0 |

ALL DIMENSIONS ARE FOR REFERENCE ONLY AND SUBJECT TO CHANGE WITHOUT NOTICE. UN-DIMENSIONED/NON-CRITICAL FEATURES MAY VARY IN SIZE AND LOCATION. COLORS MAY VARY.



Website: www.FairviewMicrowave.com
Phone: 1.800.715.4396 | 1.972.649.6678

| | |
|--|--------|
| | |
| INTERPRET ALL DIMENSIONS AND TOLERANCES PER ASME Y14.5 | |
| SCALE | SHEET |
| NONE | 1 OF 1 |

DESCRIPTION
LSZH 78 OHM TRB 3-SLOT SOLDER/CLAMP PLUG TO 3-LUG SOLDER/CLAMP NON-INSULATED BLKHD JACK FOR TWCH-78-2 TWINAX MIL-STD-1553 CABLE

| SIZE | CAGE CODE | DRAWN BY | ITEM NO. | REV |
|------|-----------|----------|----------------|-----|
| A | 3FKR5 | LNAGARAJ | FM3MSA00578-XX | A |

THE INFORMATION CONTAINED IN THIS DRAWING IS THE SOLE PROPERTY OF INFINITE ELECTRONICS, INC. ANY REPRODUCTION IN PART OR WHOLE WITHOUT THE WRITTEN PERMISSION OF INFINITE ELECTRONICS, INC. IS PROHIBITED. THESE COMMODITIES, TECHNOLOGY OR SOFTWARE WERE EXPORTED FROM THE UNITED STATES IN ACCORDANCE WITH THE EXPORT ADMINISTRATION REGULATIONS. DIVERSION CONTRARY TO U.S. LAW PROHIBITED.

6 5 4 3 2 1