

6

5

4

3

2

1

REVISION					
ZONE	REV	DESCRIPTION	DATE	CHANGED BY	APPROVED
	A	INITIAL RELEASE	07/28/2023	SREITER	EKIM

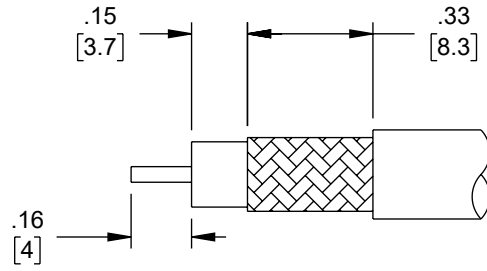
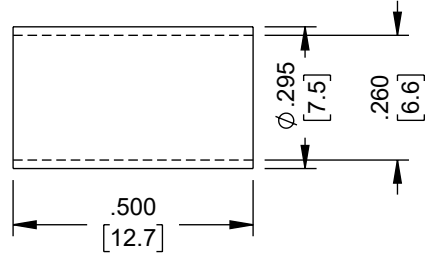
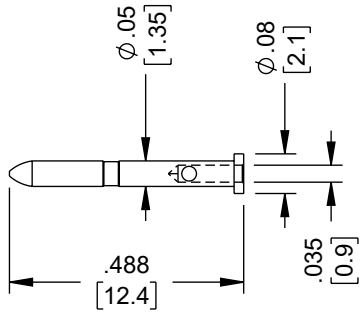
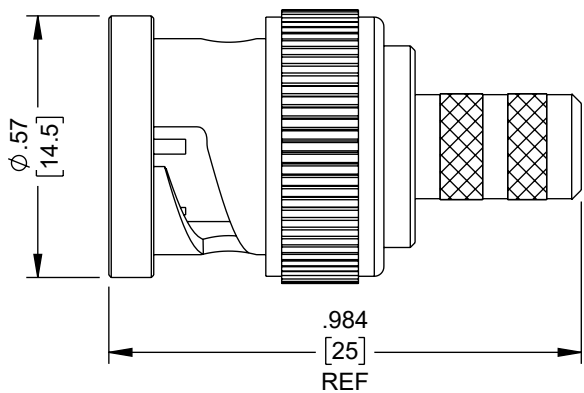

RECOMMENDED CABLE STRIPPING DIMENSIONS

NOTES:

ELECTRICAL SPECIFICATIONS:
 IMPEDENCE: 75 OHMS
 FREQUENCY RANGE: 0-3 GHz
 WORKING VOLTAGE: 500V RMS
 DIELECTRIC WITHSTAND VOLTAGE: 1500V RMS
 VSWR: 1.05 + 0.1f (GHz) DC DC to 3 GHz
 CONTACT RESISTANCE:
 CENTER CONDUCTOR: 1.3m OHM
 OUTER CONDUCTOR: 1.0m OHM
 INSULATION RESISTANCE: 5000M OHM MIN.

CABLE APPLICATIONS: 1505A, 1506A, 734A, 734D

MATERIALS:

CONTACT PIN, SLEEVE, BODY: BRASS PER QQ-B-626, ALLOY 360, 1/2H
 SPRING: BERYLLIUM COPPER
 INSULATOR: TEFLON MIL-P-19468

FINISHES:

CONTACT PIN: GOLD 30μ" OVER NICKEL 50μ" OVER COPPER 50μ"
 BODY, SLEEVE & OTHER BRASS PARTS: NICKEL 100μ" OVER COPPER 50μ"

UNLESS OTHERWISE SPECIFIED LEADING DIMENSIONS ARE INCHES DIMENSIONS IN [] ARE MILLIMETERS

TOLERANCES:

.X = ±.2 [5]	FRACTIONS ± 1/32
.XX = ±.02 [0.5]	ANGLES ± 1°
.XXX = ±.005 [0.13]	

CABLE LENGTH TOLERANCES:

≤12 [305]	= +1 [25] / -0
>12 [305] ≤ 60 [1524]	= +2 [51] / -0
>60 [1524] ≤ 120 [3048]	= +4 [102] / -0
>120 [3048] ≤ 300 [7620]	= +6 [152] / -0
>300 [7620]	= +5% / -0

ALL DIMENSIONS ARE FOR REFERENCE ONLY AND SUBJECT TO CHANGE WITHOUT NOTICE. UN-DIMENSIONED/NON-CRITICAL FEATURES MAY VARY IN SIZE AND LOCATION. COLORS MAY VARY.



Website: www.FairviewMicrowave.com
 Phone: 1.800.715.4396 | 1.972.649.6678

INTERPRET ALL DIMENSIONS AND TOLERANCES PER ASME Y14.5	
SCALE	SHEET
NONE	1 OF 1

DESCRIPTION
75 OHM BNC PLUG 1553 CONNECTOR CRIMP/SOLDER ATTACHMENT FOR TELCO DS3 734A, BELDEN 1505A, VPM2000

SIZE	CAGE CODE	DRAWN BY	ITEM NO.	REV
A	3FKR5	SREITER	FMCN10-03001-204	A

THE INFORMATION CONTAINED IN THIS DRAWING IS THE SOLE PROPERTY OF INFINITE ELECTRONICS, INC. ANY REPRODUCTION IN PART OR WHOLE WITHOUT THE WRITTEN PERMISSION OF INFINITE ELECTRONICS, INC. IS PROHIBITED. THESE COMMODITIES, TECHNOLOGY OR SOFTWARE WERE EXPORTED FROM THE UNITED STATES IN ACCORDANCE WITH THE EXPORT ADMINISTRATION REGULATIONS. DIVERSION CONTRARY TO U.S. LAW PROHIBITED.

6

5

4

3

2

1