

6

5

4

3

2

1

F

E

D

C

B

A

F

E

D

C

B

A

REVISION					
ZONE	REV	DESCRIPTION	DATE	CHANGED BY	APPROVED
	B	ECO-13202	04/18/2024	KGLEBOVA	KHIETPAS

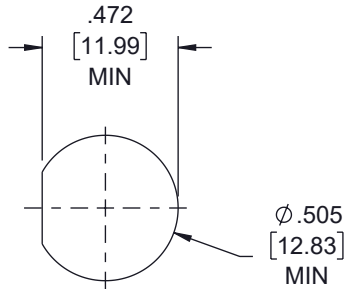
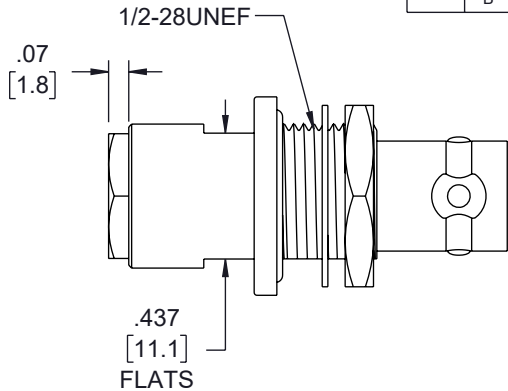

RECOMMENDED  
MOUNTING HOLE  
FOR REFERENCE ONLY

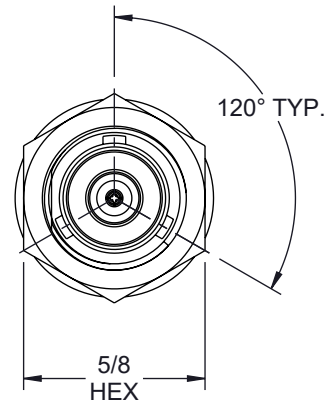
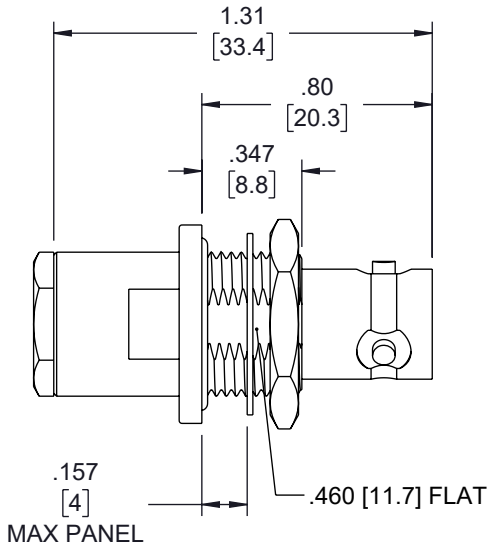
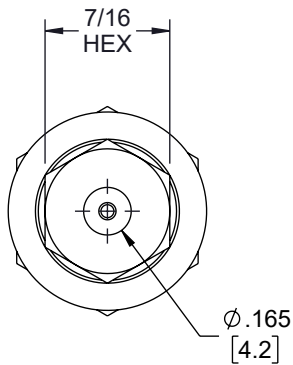

UNLESS OTHERWISE SPECIFIED  
LEADING DIMENSIONS ARE INCHES  
DIMENSIONS IN [ ] ARE MILLIMETERS

TOLERANCES:  
X = ±.2 [5] | FRACTIONS ± 1/32  
XX = ±.02 [0.5] | ANGLES ± 1°  
.XXX = ±.005 [0.13]

CABLE LENGTH TOLERANCES:  
≤12 [305] = +1 [25] / -0  
>12 [305] ≤ 60 [1524] = +2 [51] / -0  
>60 [1524] ≤ 120 [3048] = +4 [102] / -0  
>120 [3048] ≤ 300 [7620] = +6 [152] / -0  
>300 [7620] = +5% / -0

ALL DIMENSIONS ARE FOR REFERENCE ONLY  
AND SUBJECT TO CHANGE WITHOUT NOTICE  
UN-DIMENSIONED/NON-CRITICAL FEATURES  
MAY VARY IN SIZE AND LOCATION  
COLORS MAY VARY



Website: [www.FairviewMicrowave.com](http://www.FairviewMicrowave.com)  
Phone: 1.800.715.4396 | 1.972.649.6678

INTERPRET ALL DIMENSIONS AND TOLERANCES PER ASME Y14.5	
SCALE NONE	SHEET 1 OF 2

DESCRIPTION  
78 OHM TRB 3-LUG JACK NI BULKHEAD MOUNT 1553  
CONNECTOR CLAMP/SOLDER ATTACHMENT FOR M17/176-00002

SIZE A	CAGE CODE 3FKR5	DRAWN BY SREITER	ITEM NO. FMCN10-06577-206	REV B
-----------	--------------------	---------------------	------------------------------	----------

THE INFORMATION CONTAINED IN THIS DRAWING IS THE SOLE PROPERTY OF INFINITE ELECTRONICS, INC. ANY REPRODUCTION IN PART OR WHOLE WITHOUT THE WRITTEN PERMISSION OF INFINITE ELECTRONICS, INC. IS PROHIBITED. THESE COMMODITIES, TECHNOLOGY OR SOFTWARE WERE EXPORTED FROM THE UNITED STATES IN ACCORDANCE WITH THE EXPORT ADMINISTRATION REGULATIONS. DIVERSION CONTRARY TO U.S. LAW PROHIBITED.

6

5

4

3

2

1

# ASSEMBLY INSTRUCTIONS

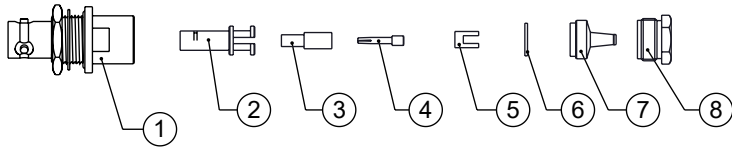

- ① BODY ASSEMBLY
- ② INNER SHIELD
- ③ DIELECTRIC
- ④ CONTACT
- ⑤ NOTCHED INSERT
- ⑥ INSULATING WASHER
- ⑦ CONE
- ⑧ CLAMP NUT

## STEP 1

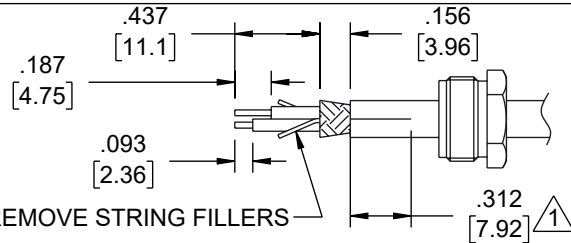

- PLACE ⑧ ONTO CABLE.
- STRIP CABLE AS SHOWN AND FLARE BRAID TO ALLOW FREE ENTER OF ⑦. (▲ LATERAL SLITS 180° APART MAY BE REQUIRED FOR INFLEXIBLE JACKET MATERIALS).
- LIGHTLY TIN CENTER CONDUCTOR.

## STEP 2

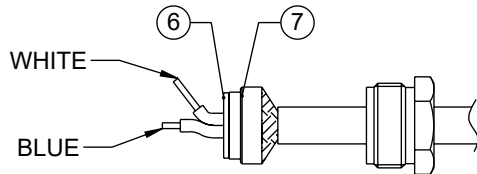

- PUSH ⑦ UNDER BRAID UNTIL BRAID IS FLUSH WITH EDGE OF ⑦.
- INSTALL ⑥ OVER CONDUCTORS AND SEAT AGAINST ⑦.
- BEND LONGER BARED CONDUCTOR AT RIGHT ANGLE AND POSITION OTHER CONDUCTOR TO CENTER OF CABLE.

## STEP 3

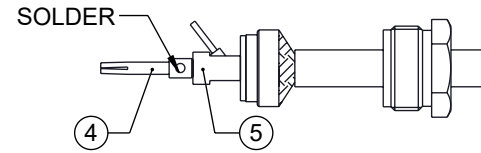

- PLACE ⑤ OVER CONDUCTORS WITH CENTER CONDUCTOR THRU CENTER HOLE AND OTHER CONDUCTOR THRU SIDE SLOT UNTIL SEATED AGAINST ⑥ OR ⑦.
- INSTALL ④ OVER CENTER CONDUCTOR. SEAT AGAINST ⑤ AND SOLDER IN PLACE.

## STEP 4

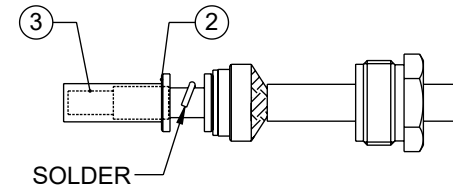

- PLACE ③ OVER ④ UNTIL BOTTOMED.
- INSTALL ② OVER ③ & ⑤ WITH CONDUCTOR THRU SIDE SLOT UNTIL BOTTOMED.
- WRAP CONDUCTOR BETWEEN ② RIDGES AND SOLDER. BEING CAREFUL NOT TO ALLOW SOLDER OR CONDUCTOR TO EXTEND ABOVE ② RIDGES.

## STEP 5

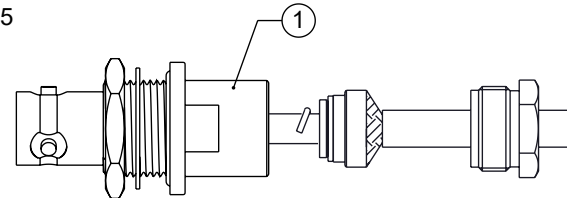

- BRING ⑧ UP ONTO TAPERED PORTION OF CABLE.
- ASSEMBLE ① OVER ENTIRE ASSY AND ENGAGE WITH ⑧.
- WRENCH TIGHTEN TO 25-35 IN LBS TORQUE.



Website: [www.FairviewMicrowave.com](http://www.FairviewMicrowave.com)  
Phone: 1.800.715.4396 | 1.972.649.6678

INTERPRET ALL DIMENSIONS AND TOLERANCES PER ASME Y14.5	
SCALE NONE	SHEET 2 OF 2

DESCRIPTION  
78 OHM TRB 3-LUG JACK NI BULKHEAD MOUNT 1553  
CONNECTOR CLAMP/SOLDER ATTACHMENT FOR M17/176-00002

SIZE A	CAGE CODE 3FKR5	DRAWN BY SREITER	ITEM NO. FMCN10-06577-206	REV B
-----------	--------------------	---------------------	------------------------------	----------

THE INFORMATION CONTAINED IN THIS DRAWING IS THE SOLE PROPERTY OF INFINITE ELECTRONICS, INC. ANY REPRODUCTION IN PART OR WHOLE WITHOUT THE WRITTEN PERMISSION OF INFINITE ELECTRONICS, INC. IS PROHIBITED. THESE COMMODITIES, TECHNOLOGY OR SOFTWARE WERE EXPORTED FROM THE UNITED STATES IN ACCORDANCE WITH THE EXPORT ADMINISTRATION REGULATIONS. DIVERSION CONTRARY TO U.S. LAW PROHIBITED.

ALL DIMENSIONS ARE FOR REFERENCE ONLY AND SUBJECT TO CHANGE WITHOUT NOTICE UN-DIMENSIONED/NON-CRITICAL FEATURES MAY VARY IN SIZE AND LOCATION COLORS MAY VARY