

6

5

4

3

2

1

F

E

D

C

B

A

F

E

D

C

B

A

REVISION					
ZONE	REV	DESCRIPTION	DATE	CHANGED BY	APPROVED
	B	ECO-13202	04/18/2024	KGLEBOVA	KHIETPAS

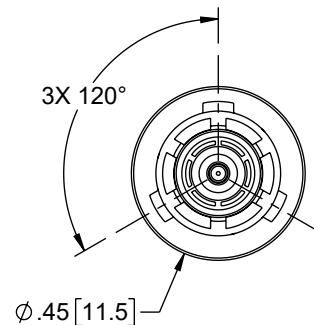
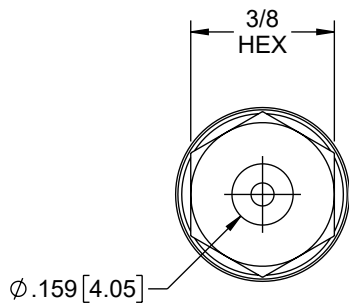
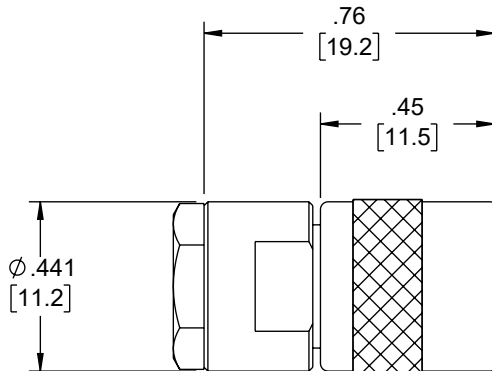
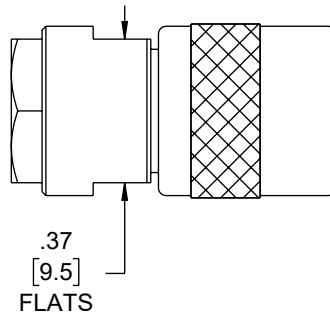

UNLESS OTHERWISE SPECIFIED
LEADING DIMENSIONS ARE INCHES
DIMENSIONS IN [] ARE MILLIMETERS

TOLERANCES:
X = ±.2 [5] FRACTIONS ± 1/32
XX = ±.02 [0.5] ANGLES ± 1°
.XXX = ±.005 [0.13]

CABLE LENGTH TOLERANCES:
≤12 [305] = +1 [25] / -0
>12 [305] ≤ 60 [1524] = +2 [51] / -0
>60 [1524] ≤ 120 [3048] = +4 [102] / -0
>120 [3048] ≤ 300 [7620] = +6 [152] / -0
>300 [7620] = +5% / -0

ALL DIMENSIONS ARE FOR REFERENCE ONLY
AND SUBJECT TO CHANGE WITHOUT NOTICE
UN-DIMENSIONED/NON-CRITICAL FEATURES
MAY VARY IN SIZE AND LOCATION
COLORS MAY VARY



Website: www.FairviewMicrowave.com
Phone: 1.800.715.4396 | 1.972.649.6678

INTERPRET ALL DIMENSIONS AND TOLERANCES PER ASME Y14.5	
SCALE NONE	SHEET 1 OF 2

DESCRIPTION
**78 OHM TRS SUBMINIATURE PLUG 1553 CONNECTOR
CRIMP/SOLDER ATTACHMENT FOR M17/176-00002**

SIZE A	CAGE CODE 3FKR5	DRAWN BY SREITER	ITEM NO. FMCN10-10030-206	REV B
-----------	--------------------	---------------------	------------------------------	----------

THE INFORMATION CONTAINED IN THIS DRAWING IS THE SOLE PROPERTY OF INFINITE ELECTRONICS, INC. ANY REPRODUCTION IN PART OR WHOLE WITHOUT THE WRITTEN PERMISSION OF INFINITE ELECTRONICS, INC. IS PROHIBITED. THESE COMMODITIES, TECHNOLOGY OR SOFTWARE WERE EXPORTED FROM THE UNITED STATES IN ACCORDANCE WITH THE EXPORT ADMINISTRATION REGULATIONS. DIVERSION CONTRARY TO U.S. LAW PROHIBITED.

6

5

4

3

2

1

ASSEMBLY INSTRUCTIONS

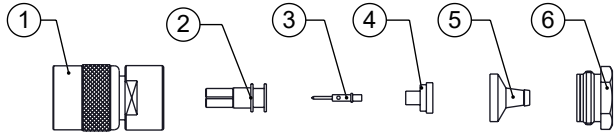

- | | |
|-----------------|-------------------------|
| ① BODY ASSEMBLY | ④ DUAL ENTRY DIELECTRIC |
| ② INNER SHIELD | ⑤ CONE |
| ③ CONTACT | ⑥ CLAMP NUT |

STEP 1

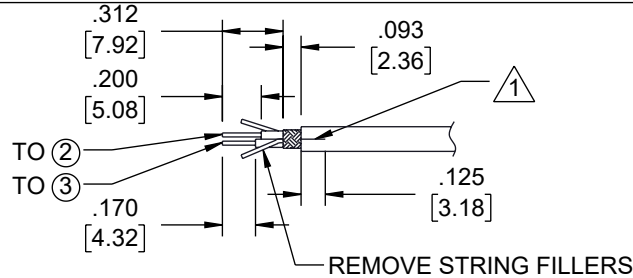

- STRIP CABLE AS SHOWN. (① LATERAL SLITS 180° APART MAY BE REQUIRED FOR INFLEXIBLE JACKET MATERIALS).

STEP 2

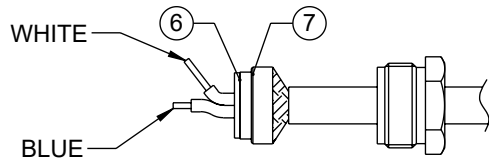

- PLACE ⑥ ONTO CABLE.
- LIGHTLY TIN CONDUCTORS AND FLARE BRAID TO ALLOW FREE ENTRY OF ⑤.

STEP 3

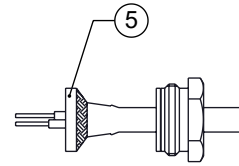

- PUSH ⑤ UNDER BRAID UNTIL BRAID IS FLUSH WITH EDGE OF ⑤.

STEP 4

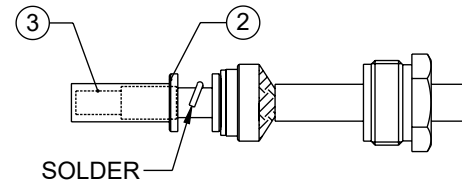

- INSERT CONDUCTORS THROUGH ④ WITH BLUE CONDUCTOR THROUGH CENTER HOLE AND WHITE CONDUCTOR THROUGH SIDE SLOT, INSTALL ③ OVER BLUE CENTER CONDUCTOR AND SOLDER.

STEP 5

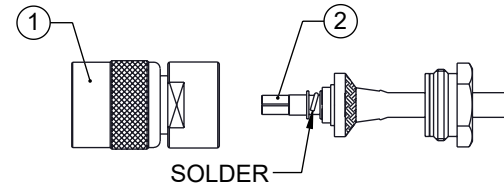

- INSERT ② OVER ③ & ④.
- SOLDER WHITE CONDUCTOR TO ②. BETWEEN RIDGES, BEING CAREFUL NOT TO ALLOW SOLDER TO EXTEND ABOVE RIDGES.
- PLACE ① OVER ENTIRE ASSEMBLY. BRING UP ⑥ TO ① AND TIGHTEN ASSEMBLY TO 25-30 IN LB TORQUE.



Website: www.FairviewMicrowave.com
 Phone: 1.800.715.4396 | 1.972.649.6678

INTERPRET ALL DIMENSIONS AND TOLERANCES PER ASME Y14.5
 SCALE: NONE SHEET: 2 OF 2

DESCRIPTION

78 OHM TRS SUBMINIATURE PLUG 1553 CONNECTOR
 CRIMP/SOLDER ATTACHMENT FOR M17/176-00002

SIZE A	CAGE CODE 3FKR5	DRAWN BY SREITER	ITEM NO. FMCN10-10030-206	REV B
-----------	--------------------	---------------------	------------------------------	----------

THE INFORMATION CONTAINED IN THIS DRAWING IS THE SOLE PROPERTY OF INFINITE ELECTRONICS, INC. ANY REPRODUCTION IN PART OR WHOLE WITHOUT THE WRITTEN PERMISSION OF INFINITE ELECTRONICS, INC. IS PROHIBITED. THESE COMMODITIES, TECHNOLOGY OR SOFTWARE WERE EXPORTED FROM THE UNITED STATES IN ACCORDANCE WITH THE EXPORT ADMINISTRATION REGULATIONS. DIVERSION CONTRARY TO U.S. LAW PROHIBITED.

ALL DIMENSIONS ARE FOR REFERENCE ONLY AND SUBJECT TO CHANGE WITHOUT NOTICE. UN-DIMENSIONED/NON-CRITICAL FEATURES MAY VARY IN SIZE AND LOCATION. COLORS MAY VARY.