

6 5 4 3 2 1

REVISION					
ZONE	REV	DESCRIPTION	DATE	CHANGED BY	APPROVED
	B	ECO-13202	04/30/2024	KGLEBOVA	KHIETPAS

F

F

E

E

D

D

C

C

B

B

A

A

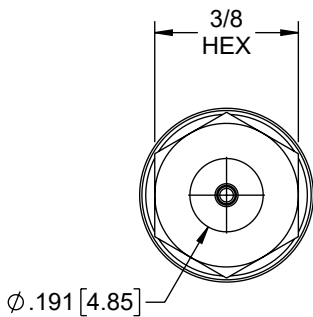
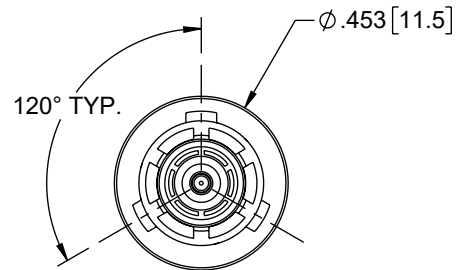
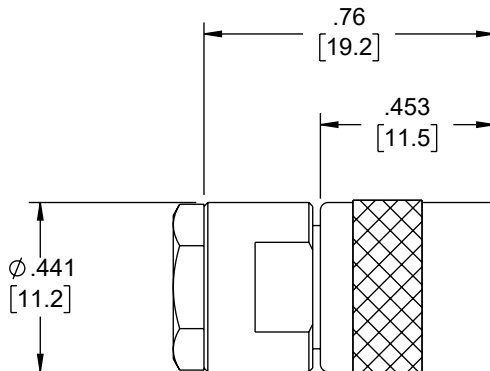
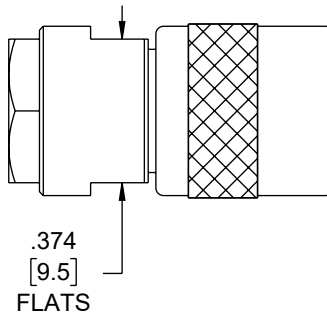

UNLESS OTHERWISE SPECIFIED  
LEADING DIMENSIONS ARE INCHES  
DIMENSIONS IN [ ] ARE MILLIMETERS

TOLERANCES:  
X = ±.2 [5] | FRACTIONS ± 1/32  
XX = ±.02 [0.5] | ANGLES ± 1°  
.XXX = ±.005 [0.13]

CABLE LENGTH TOLERANCES:  
≤12 [305] = +1 [25] / -0  
>12 [305] ≤ 60 [1524] = +2 [51] / -0  
>60 [1524] ≤ 120 [3048] = +4 [102] / -0  
>120 [3048] ≤ 300 [7620] = +6 [152] / -0  
>300 [7620] = +5% / -0

ALL DIMENSIONS ARE FOR REFERENCE ONLY  
AND SUBJECT TO CHANGE WITHOUT NOTICE  
UN-DIMENSIONED/NON-CRITICAL FEATURES  
MAY VARY IN SIZE AND LOCATION  
COLORS MAY VARY



Website: [www.FairviewMicrowave.com](http://www.FairviewMicrowave.com)  
Phone: 1.800.715.4396 | 1.972.649.6678

INTERPRET ALL DIMENSIONS AND  
TOLERANCES PER ASME Y14.5

SCALE NONE SHEET 1 OF 2

DESCRIPTION  
78 OHM TRS SUBMINIATURE 3-SLOT PLUG 1553 CONNECTOR  
CRIMP/SOLDER ATTACHMENT FOR FMBC-30-02003, TWC-78-1

SIZE	CAGE CODE	DRAWN BY	ITEM NO.	REV
A	3FKR5	SREITER	FMCN10-10030-231	B

THE INFORMATION CONTAINED IN THIS DRAWING IS THE SOLE PROPERTY OF INFINITE ELECTRONICS, INC. ANY REPRODUCTION IN PART OR WHOLE WITHOUT THE WRITTEN PERMISSION OF INFINITE ELECTRONICS, INC. IS PROHIBITED. THESE COMMODITIES, TECHNOLOGY OR SOFTWARE WERE EXPORTED FROM THE UNITED STATES IN ACCORDANCE WITH THE EXPORT ADMINISTRATION REGULATIONS. DIVERSION CONTRARY TO U.S. LAW PROHIBITED.

6 5 4 3 2 1

# ASSEMBLY INSTRUCTIONS

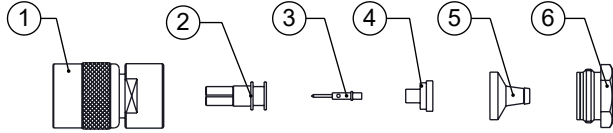

- ① BODY ASSEMBLY
- ② INNER SHIELD
- ③ CONTACT
- ④ DUAL ENTRY DIELECTRIC
- ⑤ CONE
- ⑥ CLAMP NUT

## STEP 3

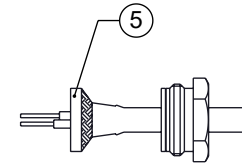

- PUSH ⑤ UNDER BRAID UNTIL BRAID IS FLUSH WITH EDGE OF ⑤.

## STEP 1

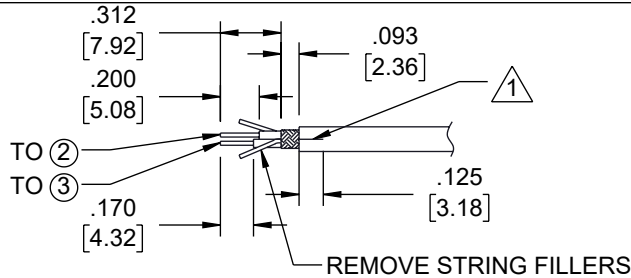

- STRIP CABLE AS SHOWN. (⚠ LATERAL SLITS 180° APART MAY BE REQUIRED FOR INFLEXIBLE JACKET MATERIALS).

## STEP 4

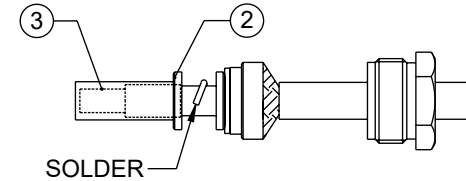

- INSERT CONDUCTORS THROUGH ④ WITH BLUE CONDUCTOR THROUGH CENTER HOLE AND WHITE CONDUCTOR THROUGH SIDE SLOT, INSTALL ③ OVER BLUE CENTER CONDUCTOR AND SOLDER.

## STEP 2

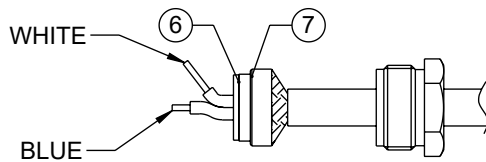

- PLACE ⑥ ONTO CABLE.
- LIGHTLY TIN CONDUCTORS AND FLARE BRAID TO ALLOW FREE ENTRY OF ⑤.

## STEP 5

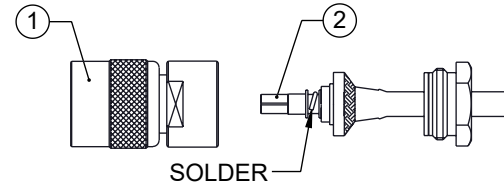

- INSERT ② OVER ③ & ④.
- SOLDER WHITE CONDUCTOR TO ②. BETWEEN RIDGES, BEING CAREFUL NOT TO ALLOW SOLDER TO EXTEND ABOVE RIDGES.
- PLACE ① OVER ENTIRE ASSEMBLY. BRING UP ⑥ TO ① AND TIGHTEN ASSEMBLY TO 25-30 IN LB TORQUE.



Website: [www.FairviewMicrowave.com](http://www.FairviewMicrowave.com)  
 Phone: 1.800.715.4396 | 1.972.649.6678

INTERPRET ALL DIMENSIONS AND TOLERANCES PER ASME Y14.5

SCALE NONE SHEET 2 OF 2

### DESCRIPTION

78 OHM TRS SUBMINIATURE 3-SLOT PLUG 1553 CONNECTOR  
 CRIMP/SOLDER ATTACHMENT FOR FMBC-30-02003, TWC-78-1

SIZE	CAGE CODE	DRAWN BY	ITEM NO.	REV
A	3FKR5	SREITER	FMCN10-10030-231	B

THE INFORMATION CONTAINED IN THIS DRAWING IS THE SOLE PROPERTY OF INFINITE ELECTRONICS, INC. ANY REPRODUCTION IN PART OR WHOLE WITHOUT THE WRITTEN PERMISSION OF INFINITE ELECTRONICS, INC. IS PROHIBITED. THESE COMMODITIES, TECHNOLOGY OR SOFTWARE WERE EXPORTED FROM THE UNITED STATES IN ACCORDANCE WITH THE EXPORT ADMINISTRATION REGULATIONS. DIVERSION CONTRARY TO U.S. LAW PROHIBITED.

ALL DIMENSIONS ARE FOR REFERENCE ONLY AND SUBJECT TO CHANGE WITHOUT NOTICE UN-DIMENSIONED/NON-CRITICAL FEATURES MAY VARY IN SIZE AND LOCATION COLORS MAY VARY