

REVISIONS			
REV.	DESCRIPTION	DATE	APPROVED
A	INITIAL RELEASE	11/21/19	S ELLIS

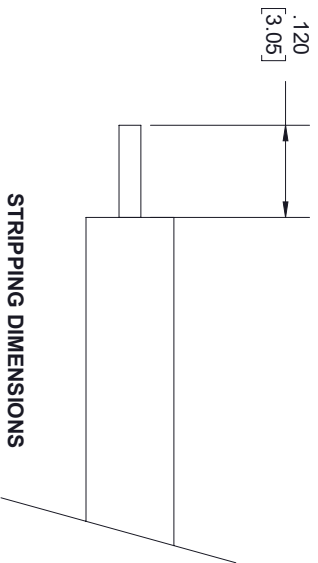
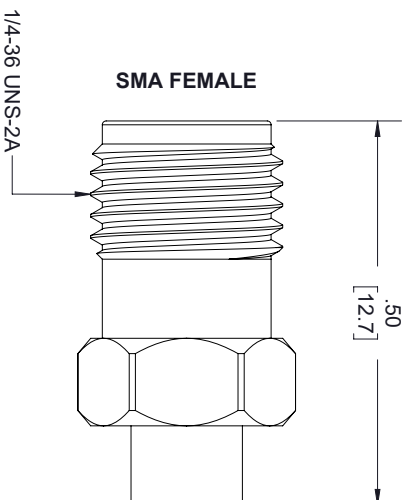
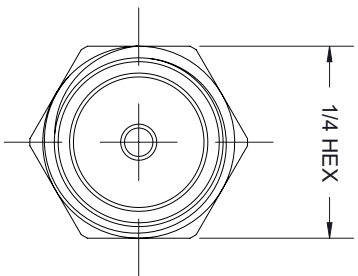

STRIPPING DIMENSIONS

NOTES:

- CABLE ATTACHMENT:
 - OUTER: SOLDER.
 - INNER: SOLDER.

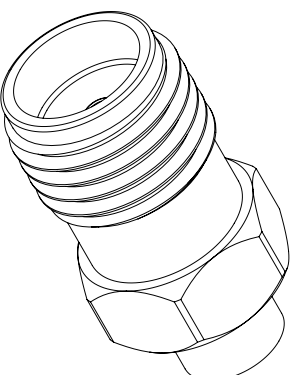

THESE COMMODITIES, TECHNOLOGY OR SOFTWARE WERE EXPORTED FROM THE UNITED STATES IN ACCORDANCE WITH THE EXPORT ADMINISTRATION REGULATIONS, DIVERSION CONTRARY TO U.S. LAW PROHIBITED.



TITLE

UNLESS OTHERWISE SPECIFIED LEADING DIMENSIONS ARE INCHES DIMENSIONS IN [] ARE MILLIMETERS				THIRD-ANGLE PROJECTION	
TOLERANCES:					
CABLE LENGTH (L) TOLERANCES:				THE INFORMATION AND DESIGN IN THIS DOCUMENT IS THE PROPERTY OF FAIRVIEW MICROWAVE CORPORATION. ALL RIGHTS RESERVED.	
X = ±.2	[.008]	FRACTIONS	L ± 1/2 B(05) = +1 [25] / -0	SCALE	
XX = ±.02	[.51]	± 1/32	12 [305] < L ≤ 60 [1524] = +2 [51] / -0	N/A	
XXX = ±.005	[.13]	ANGLES ± 1°	60 [1524] < L ≤ 120 [3048] = +4 [102] / -0	REV	
			120 [3048] < L ≤ 300 [7620] = +6 [152] / -0	A	
			300 [7620] < L = +5%L / -0	OF	
ALL DIMENSIONS SHOWN ARE FOR REFERENCE ONLY.				1	
SIZE	CAGE CODE	DRAWN BY	PART NUMBER	REV	
A	3FKR5	K.DANG	FMCM1418	A	