

REVISIONS			
REV.	DESCRIPTION	DATE	APPROVED
A	INITIAL RELEASE	9/20/2021	SRAUTUS

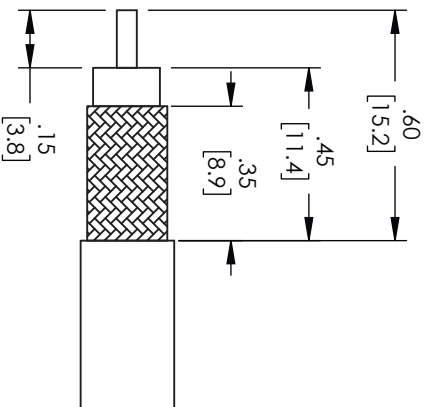

**STRIPPING DIMENSIONS**

**CRIMP SIZE REQUIRED**  
**CONTACT: .068" HEX CRIMP TOOL**  
**FERRULE: .213" HEX CRIMP TOOL**

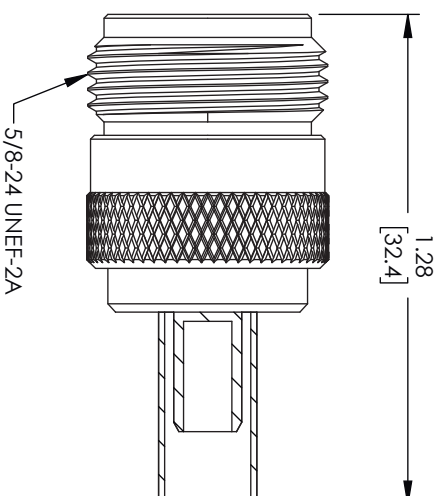
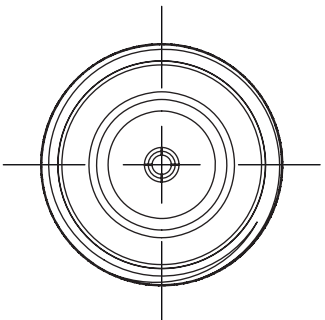
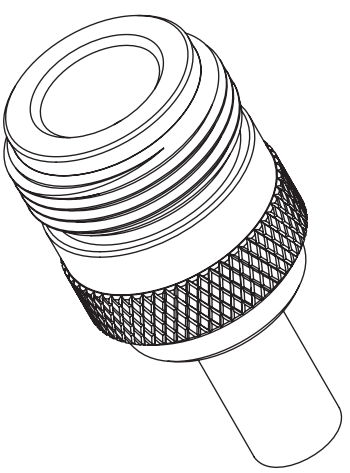

THESE COMMODITIES, TECHNOLOGY OR SOFTWARE WERE EXPORTED FROM THE UNITED STATES IN ACCORDANCE WITH THE EXPORT ADMINISTRATION REGULATIONS, DIVERSION CONTRARY TO U.S. LAW PROHIBITED.



TITLE

UNLESS OTHERWISE SPECIFIED LEADING DIMENSIONS ARE INCHES DIMENSIONS IN [ ] ARE MILLIMETERS				THIRD-ANGLE PROJECTION	
TOLERANCES:					
CABLE LENGTH (L) TOLERANCES:		THE INFORMATION AND DESIGN IN THIS DOCUMENT IS THE PROPERTY OF FAIRVIEW MICROWAVE CORPORATION. ALL RIGHTS RESERVED.			
X = ±.2	[.08]	FRACTIONS	L ≤ 12 [305] = +1 [25] / -0	SHEET 1 OF 1	
XX = ±.02	[.51]	± 1/32	12 [305] < L ≤ 60 [1524] = +2 [51] / -0	SCALE N/A	
XXX = ±.005	[.13]	ANGLES ± 1°	60 [1524] < L ≤ 120 [3048] = +4 [102] / -0	REV A	
			120 [3048] < L ≤ 300 [7620] = +6 [152] / -0	ITEM NO. FMCN1760	
			300 [7620] < L = +5%L / -0	DRAWN BY DMAY	
ALL DIMENSIONS SHOWN ARE FOR REFERENCE ONLY.				GAGE CODE 3FKRS	
SIZE A				REV A	