

REVISIONS			
REV.	DESCRIPTION	DATE	APPROVED
A	INITIAL RELEASE	9/27/2021	SRAUTUS

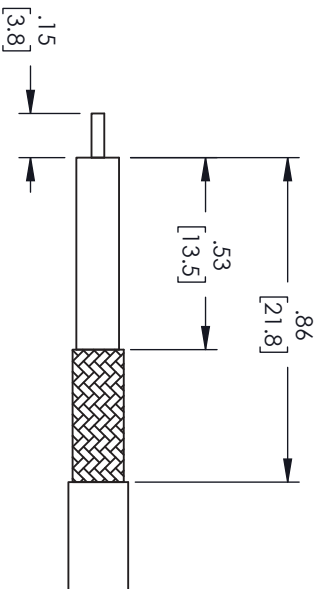

STRIPPING DIMENSIONS

CRIMP SIZE REQUIRED
CONTACT: SOLDER
FERRULE: .213" HEX CRIMP TOOL

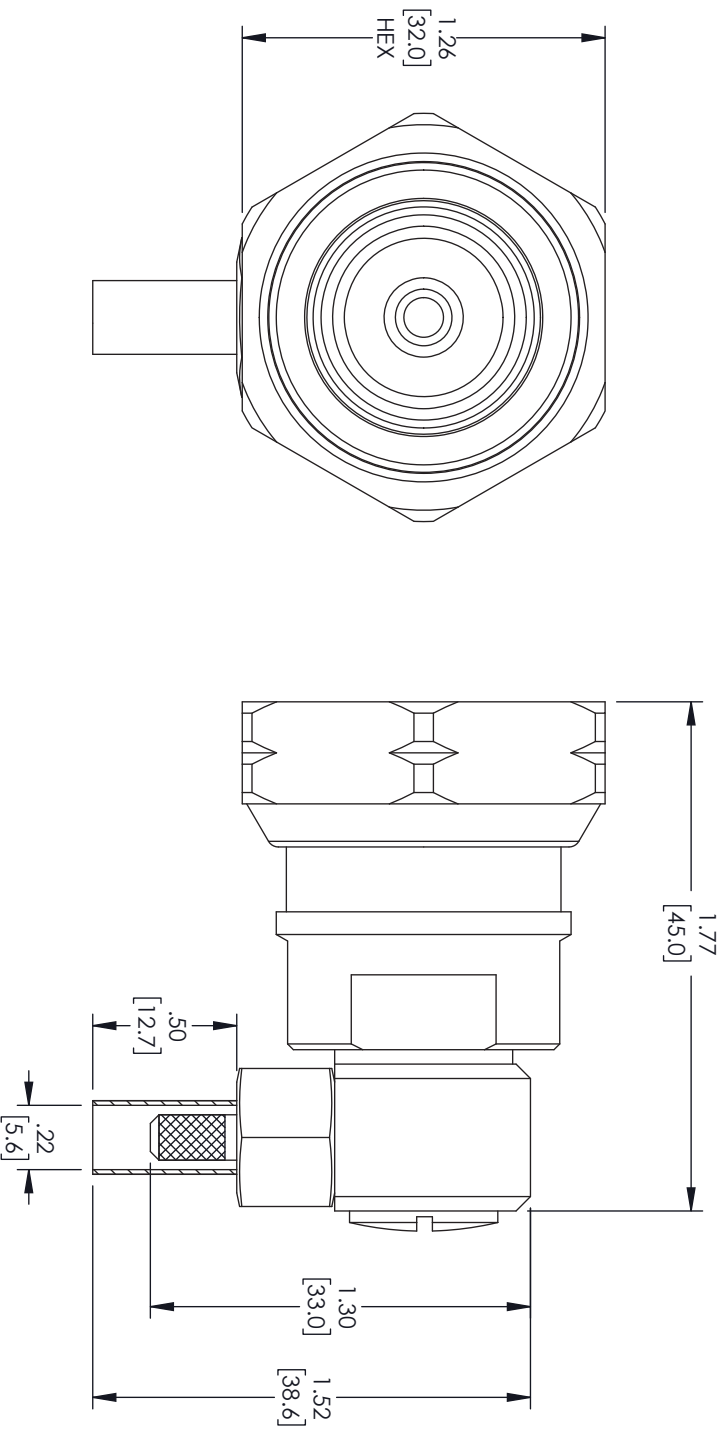
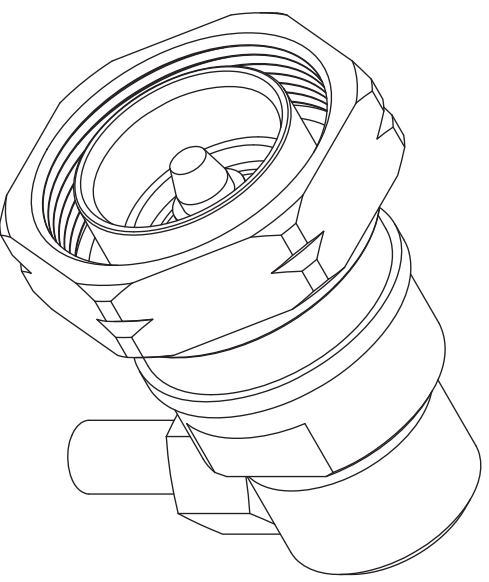

THESE COMMODITIES, TECHNOLOGY OR SOFTWARE WERE EXPORTED FROM THE UNITED STATES IN ACCORDANCE WITH THE EXPORT ADMINISTRATION REGULATIONS, DIVERSION CONTRARY TO U.S. LAW PROHIBITED.



an INFINITI® brand

TITLE

UNLESS OTHERWISE SPECIFIED LEADING DIMENSIONS ARE INCHES DIMENSIONS IN [] ARE MILLIMETERS				THIRD-ANGLE PROJECTION	
TOLERANCES:					
CABLE LENGTH (L) TOLERANCES:				THE INFORMATION AND DESIGN IN THIS DOCUMENT IS THE PROPERTY OF FAIRVIEW MICROWAVE CORPORATION. ALL RIGHTS RESERVED.	
X = ±.2 [5.08]		FRACTIONS ± 1/32		L ≤ 12 [305] = +1 [25] / -0	
XX = ±.02 [.51]		± 1/32		12 [305] < L ≤ 60 [1524] = +2 [51] / -0	
XXX = ±.005 [.13]		ANGLES ± 1°		60 [1524] < L ≤ 120 [3048] = +4 [102] / -0	
				120 [3048] < L ≤ 300 [7620] = +6 [152] / -0	
				300 [7620] < L = +5%L / -0	
ALL DIMENSIONS SHOWN ARE FOR REFERENCE ONLY.					
SIZE	GAGE CODE	DRAWN BY	ITEM NO.	SCALE	REV
A	3FKRS	DMAY	FMCN1762	N/A	A