

REVISIONS			
REV.	DESCRIPTION	DATE	APPROVED
A	INITIAL RELEASE	02/11/2022	A.GANWANI

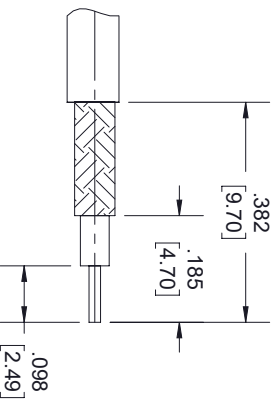
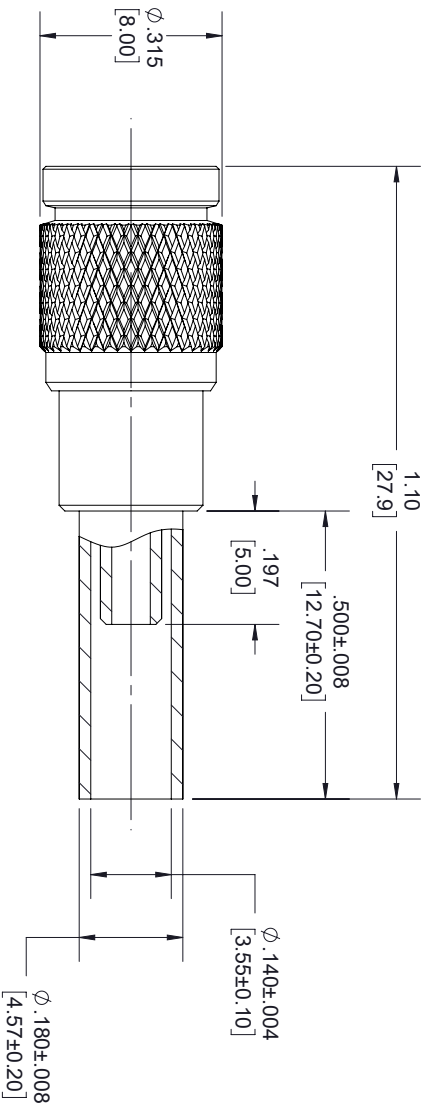

STRIPPING DIMENSIONS

NOTES:

- CABLE ATTACHMENT:
 - OUTER: CRIMP.
 - INNER: SOLDER/CRIMP.
- CRIMP SIZE REQUIRED:
 - CONTACT: .36" [0.92] SQ CRIMP TOOL.
 - FERRULE: .151" [3.84] HEX CRIMP TOOL.

THESE COMMODITIES, TECHNOLOGY OR SOFTWARE WERE EXPORTED FROM THE UNITED STATES IN ACCORDANCE WITH THE EXPORT ADMINISTRATION REGULATIONS, DIVERSION CONTRARY TO U.S. LAW PROHIBITED.



an INFINITI® brand

TITLE

UNLESS OTHERWISE SPECIFIED LEADING DIMENSIONS ARE INCHES		THIRD-ANGLE PROJECTION	
DIMENSIONS IN [] ARE MILLIMETERS			
TOLERANCES:		THE INFORMATION AND DESIGN IN THIS DOCUMENT IS THE PROPERTY OF FAIRVIEW MICROWAVE CORPORATION. ALL RIGHTS RESERVED.	
CABLE LENGTH (L) TOLERANCES:		SHEET 1 OF 1	
L ± 1/2 (806) = +1/2 (51) / -0 12 (305) < L ≤ 60 (1524) = ± 2 (51) / -0 60 (1524) < L ≤ 120 (3048) = ± 4 (102) / -0 120 (3048) < L ≤ 300 (7620) = ± 6 (152) / -0 300 (7620) < L = +5% / -0		SCALE	
ALL DIMENSIONS SHOWN ARE FOR REFERENCE ONLY.		N/A	
SIZE	GAGE CODE	DRAWN BY	ITEM NO.
A	3FKRS	K.GLEBOVA	FMCN1823
			REV
			A