

REVISIONS			
REV.	DESCRIPTION	DATE	APPROVED
A	INITIAL RELEASE	02/11/2022	A.GANWANI

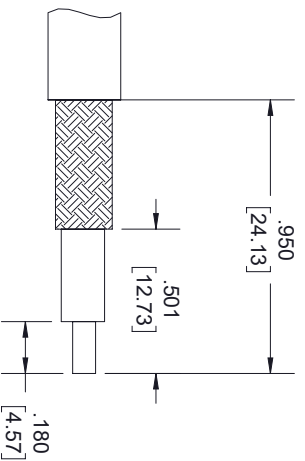
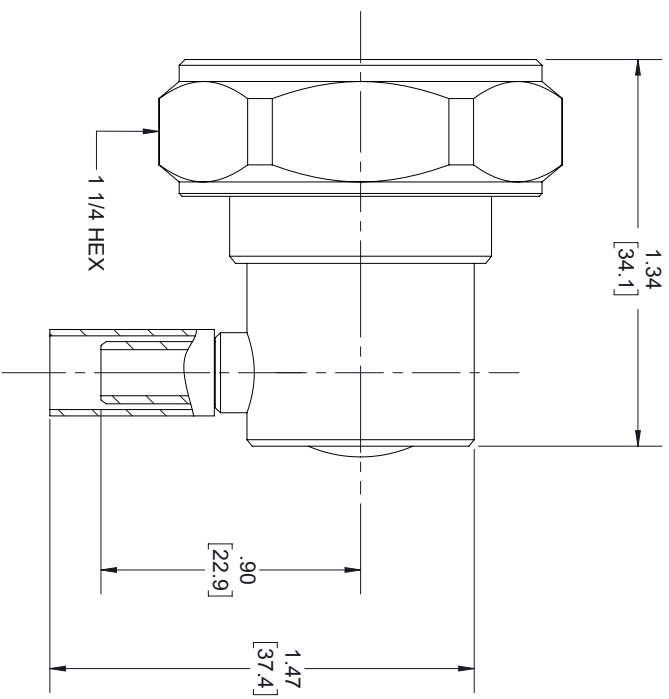

STRIPPING DIMENSIONS

ASSEMBLY PROCEDURES

1. STRIP CABLE AS SHOWN. SLIDE FERRULE OVER CABLE.
2. INSTALL CABLE INTO BODY OF CONNECTOR AND SOFT SOLDER CENTER CONDUCTOR IN PLACE.
3. CRIMP FERRULE AND PRESS CAP DOWN.

CRIMP SIZE REQUIRED

FERRULE: .255" [6.48] HEX CRIMP TOOL.

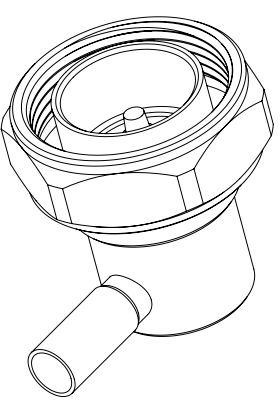

THESE COMMODITIES, TECHNOLOGY OR SOFTWARE WERE EXPORTED FROM THE UNITED STATES IN ACCORDANCE WITH THE EXPORT ADMINISTRATION REGULATIONS, DIVERSION CONTRARY TO U.S. LAW PROHIBITED.



TITLE

UNLESS OTHERWISE SPECIFIED LEADING DIMENSIONS ARE INCHES DIMENSIONS IN [] ARE MILLIMETERS				THIRD-ANGLE PROJECTION	
TOLERANCES:					
CABLE LENGTH (L) TOLERANCES:		THE INFORMATION AND DESIGN IN THIS DOCUMENT IS THE PROPERTY OF FAIRVIEW MICROWAVE CORPORATION. ALL RIGHTS RESERVED.			
X = ±.2	[5.08]	FRACTIONS	±.125	±.125	±.125
XX = ±.02	[.51]	±.1/32	±.1/32	±.1/32	±.1/32
XXX = ±.005	[.13]	ANGLES ± 1°	±.1	±.1	±.1
L ≤ 12 [305] = +1 [25] / -0		SCALE			
12 [305] < L ≤ 60 [1524] = +2 [51] / -0		N/A			
60 [1524] < L ≤ 120 [3048] = +4 [102] / -0		REV			
120 [3048] < L ≤ 300 [7620] = +6 [152] / -0		A			
300 [7620] < L = +5% / -0		REV			
ALL DIMENSIONS SHOWN ARE FOR REFERENCE ONLY.		A			
SIZE	GAGE CODE	DRAWN BY	ITEM NO.	REV	
A	3FKRS	K.GLEBOVA	FMCN1833	A	