

REVISIONS			
REV.	DESCRIPTION	DATE	APPROVED
A	INITIAL RELEASE	02/11/2022	AGANWANI

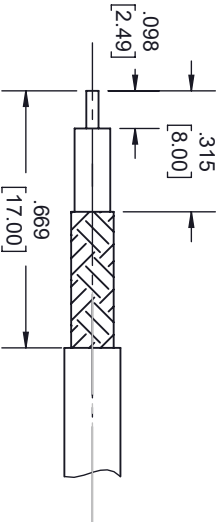
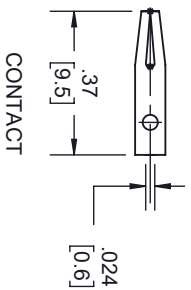
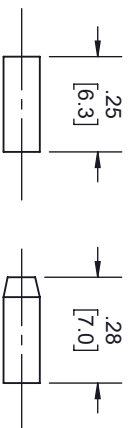
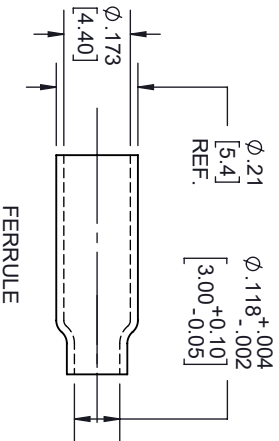

STRIPPING DIMENSION

NOTES:

- CABLE ATTACHMENT:
 - OUTER: CRIMP.
 - INNER: SOLDER/CRIMP.
- CRIMP SIZE REQUIRED:
 - CONTACT: .71" [1.8] SQ CRIMP TOOL.
 - FERRULE: .146" [3.7] HEX CRIMP TOOL.
 - .185" [4.7] HEX CRIMP TOOL.

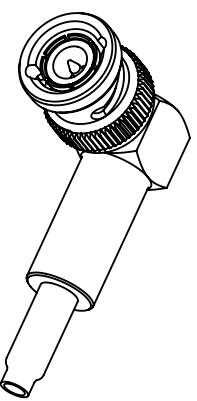
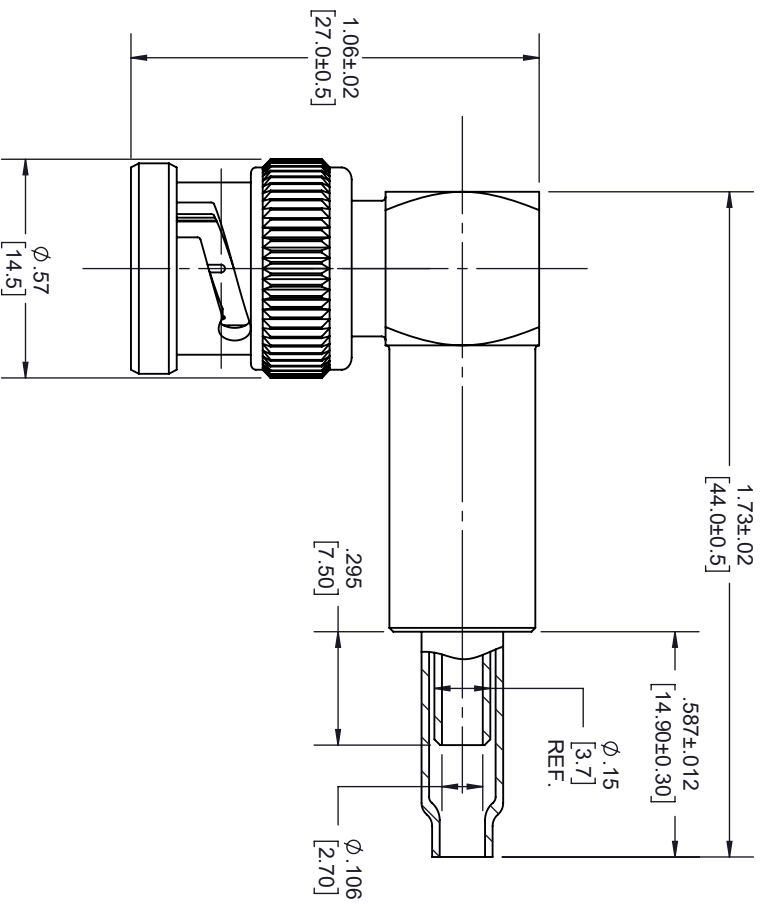

THESE COMMODITIES, TECHNOLOGY OR SOFTWARE WERE EXPORTED FROM THE UNITED STATES IN ACCORDANCE WITH THE EXPORT ADMINISTRATION REGULATIONS, DIVERSION CONTRARY TO U.S. LAW PROHIBITED.



UNLESS OTHERWISE SPECIFIED LEADING DIMENSIONS ARE INCHES
DIMENSIONS IN [] ARE MILLIMETERS

TOLERANCES:

CABLE LENGTH (L) TOLERANCES:	THIRD-ANGLE PROJECTION
L ≤ 12 [305] = +1 [25] / -0	THE INFORMATION AND DESIGN IN THIS DOCUMENT IS THE PROPERTY OF FAIRVIEW MICROWAVE CORPORATION. ALL RIGHTS RESERVED.
12 [305] < L ≤ 60 [1524] = +2 [51] / -0	
60 [1524] < L ≤ 120 [3048] = +4 [102] / -0	
120 [3048] < L ≤ 300 [7620] = +6 [152] / -0	
300 [7620] < L = +5%L / -0	

FRACTIONS ± 1/32

ANGLES ± 1°

SCALE 1 OF 1

SIZE	GAGE CODE	DRAWN BY	ITEM NO.	REV
A	3FKRS	K.GLEBOVA	FMCN1838	A

TITLE