

REVISIONS			
REV.	DESCRIPTION	DATE	APPROVED
A	INITIAL RELEASE	02/21/2022	AGANWANI

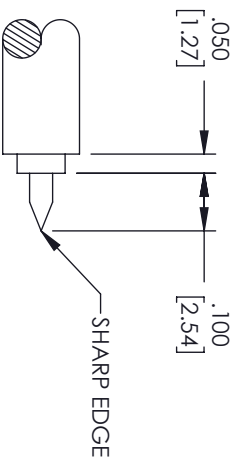
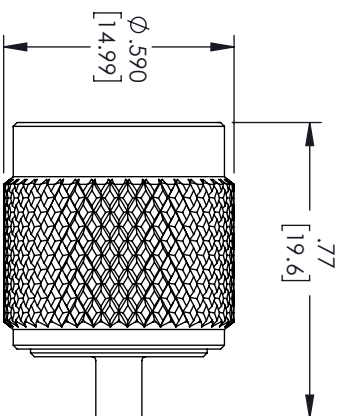

STRIPPING DIMENSIONS

ASSEMBLY PROCEDURE

1. STRIP CABLE AS SHOWN. DO NOT NICK CENTER CONDUCTOR.
2. INSERT CABLE INTO BODY UNTIL CENTER CONDUCTOR PLUGS INTO CONTACT. SOLDER OUTER CONDUCTOR TO BODY.

THESE COMMODITIES, TECHNOLOGY OR SOFTWARE WERE EXPORTED FROM THE UNITED STATES IN ACCORDANCE WITH THE EXPORT ADMINISTRATION REGULATIONS, DIVERSION CONTRARY TO U.S. LAW PROHIBITED.



TITLE

UNLESS OTHERWISE SPECIFIED LEADING DIMENSIONS ARE INCHES DIMENSIONS IN [ ] ARE MILLIMETERS				THIRD-ANGLE PROJECTION	
TOLERANCES:					
CABLE LENGTH (L) TOLERANCES:		THE INFORMATION AND DESIGN IN THIS DOCUMENT IS THE PROPERTY OF FAIRVIEW MICROWAVE CORPORATION. ALL RIGHTS RESERVED.			
X = ±.2	[.008]	FRACTIONS	L ≤ 12 [305]	= +1 [25] / -0	SCALE
XX = ±.02	[.51]	± 1/32	12 [305] < L ≤ 60 [1524]	= +2 [51] / -0	
XXX = ±.005	[.13]	ANGLES ± 1°	60 [1524] < L ≤ 120 [3048]	= +4 [102] / -0	
120 [3048] < L ≤ 300 [7620]		= +6 [152] / -0	300 [7620] < L = +5%/ -0		
ALL DIMENSIONS SHOWN ARE FOR REFERENCE ONLY.					
SIZE	GAGE CODE	DRAWN BY	ITEM NO.	REV	
A	3FKRS	A.KRESOWSKI	FMCN1875	A	N/A