

REVISIONS			
REV.	DESCRIPTION	DATE	APPROVED
A	INITIAL RELEASE	02/21/2022	AGANWANI

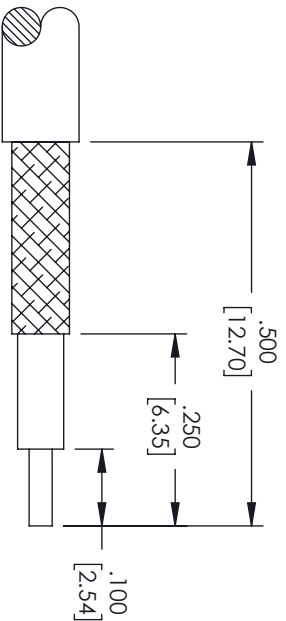
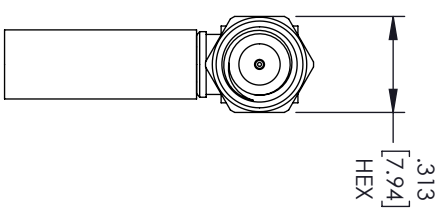
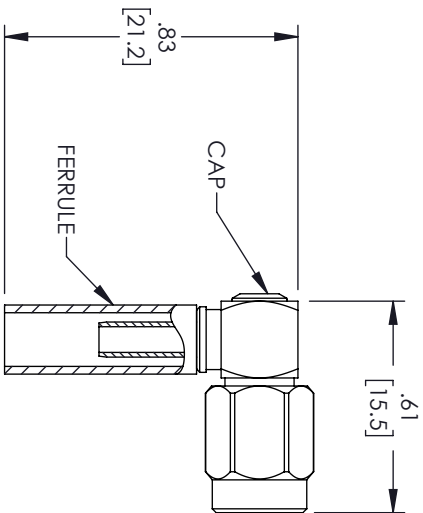
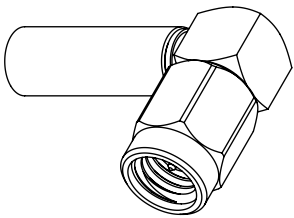

STRIPPING DIMENSIONS

ASSEMBLY INSTRUCTIONS

1. STRIP CABLE AS SHOWN AND TIN CENTER CONDUCTOR. SLIDE FERRULE OVER CABLE.
2. INSTALL CABLE INTO BODY OF CONNECTOR AND SOFT SOLDER CENTER CONDUCTOR INTO PLACE.
3. CRIMP FERRULE AND PRESS CAP INTO PLACE.

CRIMP SIZE REQUIRED

CONTACT: SOLDER
FERRULE: .128 [3.25] HEX CRIMP TOOL

THESE COMMODITIES, TECHNOLOGY OR SOFTWARE WERE EXPORTED FROM THE UNITED STATES IN ACCORDANCE WITH THE EXPORT ADMINISTRATION REGULATIONS, DIVERSION CONTRARY TO U.S. LAW PROHIBITED.



TITLE

UNLESS OTHERWISE SPECIFIED LEADING DIMENSIONS ARE INCHES DIMENSIONS IN [] ARE MILLIMETERS				THIRD-ANGLE PROJECTION	
TOLERANCES:					
CABLE LENGTH (L) TOLERANCES:		L ≤ 12 [305] = +1 [25] / -0 12 [305] < L ≤ 60 [1524] = +2 [51] / -0 60 [1524] < L ≤ 120 [3048] = +4 [102] / -0 120 [3048] < L ≤ 300 [7620] = +6 [152] / -0 300 [7620] < L = +5%L / -0			
FRACTIONS		THE INFORMATION AND DESIGN IN THIS DOCUMENT IS THE PROPERTY OF FAIRVIEW MICROWAVE CORPORATION. ALL RIGHTS RESERVED.			
X = ±.2 [5.08] XX = ±.02 [.51] XXX = ±.005 [.13]		ANGLES ± 1°		SHEET 1 OF 1	
ALL DIMENSIONS SHOWN ARE FOR REFERENCE ONLY.					
SIZE	GAGE CODE	DRAWN BY	ITEM NO.	SCALE	REV
A	3FKRS	A.KRESOWSKI	FMCN1884	N/A	A