

REVISIONS			
REV.	DESCRIPTION	DATE	APPROVED
A	INITIAL RELEASE	02/22/2022	AGANWANI

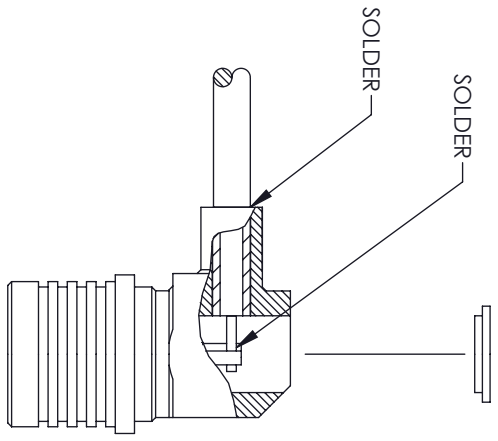

STRIPPING DIMENSIONS

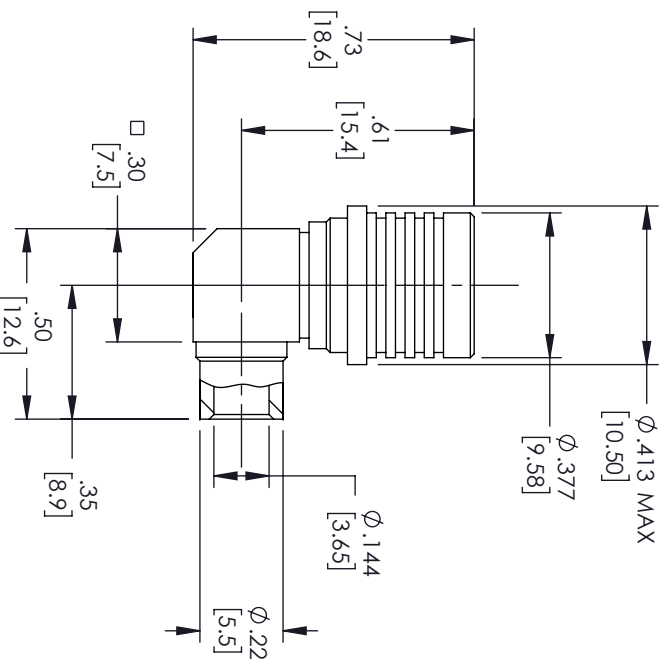

ASSEMBLY PROCEDURE

1. STRIP CABLE AS SHOWN AND TIN CENTER CONDUCTOR.
2. SOLDER CENTER CONDUCTOR TO THE CONTACT IN CONNECTOR BODY. SOLDER SHIELD TO BODY AS SHOWN.
3. PRESS CAP INTO PLACE.

THESE COMMODITIES, TECHNOLOGY OR SOFTWARE WERE EXPORTED FROM THE UNITED STATES IN ACCORDANCE WITH THE EXPORT ADMINISTRATION REGULATIONS, DIVERSION CONTRARY TO U.S. LAW PROHIBITED.



TITLE

UNLESS OTHERWISE SPECIFIED LEADING DIMENSIONS ARE INCHES DIMENSIONS IN [ ] ARE MILLIMETERS		THIRD-ANGLE PROJECTION	
TOLERANCES:		THE INFORMATION AND DESIGN IN THIS DOCUMENT IS THE PROPERTY OF FAIRVIEW MICROWAVE CORPORATION. ALL RIGHTS RESERVED.	
X = ±.2	[.008]	FRACTIONS	L ± 1/2 B065 = +1 [25] / -0
XX = ±.02	[.51]	± 1/32	12 [1305] < L ≤ 60 [1524] = +2 [51] / -0
XXX = ±.005	[.13]	ANGLES ± 1°	60 [1524] < L ≤ 120 [3048] = +4 [102] / -0
			120 [3048] < L ≤ 300 [7620] = +6 [152] / -0
			300 [7620] < L = +5% / -0
ALL DIMENSIONS SHOWN ARE FOR REFERENCE ONLY.	SCALE	SHEET 1 OF 1	
SIZE A	GAGE CODE 3FKRS	DRAWN BY AKRESOWSK	ITEM NO. FMCN1889
			REV A