

REVISIONS			
REV.	DESCRIPTION	DATE	APPROVED
A	INITIAL RELEASE	06/07/22	AGANWANI

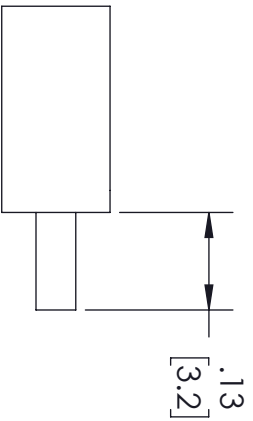

STRIPPING DIMENSIONS

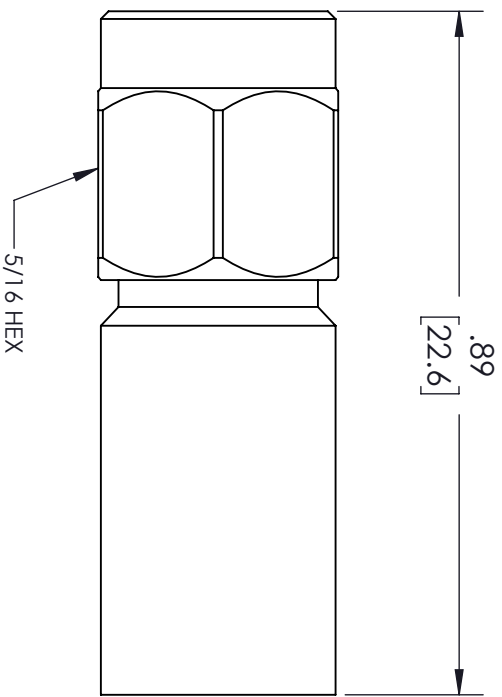

ASSEMBLY PROCEDURES

1. STRIP CABLE AS SHOWN, DO NOT NICK CENTER CONDUCTOR.
2. SOLDER CONTACT TO CENTER CONDUCTOR. REMOVE EXCESS SOLDER.
3. INSERT CABLE INTO BODY UNTIL OUTER CONDUCTOR BOTTOMS ON WITH BODY SHOULDER. SOLDER OUTER CONDUCTOR TO BODY.

THESE COMMODITIES, TECHNOLOGY OR SOFTWARE WERE EXPORTED FROM THE UNITED STATES IN ACCORDANCE WITH THE EXPORT ADMINISTRATION REGULATIONS, DIVERSION CONTRARY TO U.S. LAW PROHIBITED.



TITLE

UNLESS OTHERWISE SPECIFIED LEADING DIMENSIONS ARE INCHES DIMENSIONS IN [] ARE MILLIMETERS		THIRD-ANGLE PROJECTION	
TOLERANCES:		THE INFORMATION AND DESIGN IN THIS DOCUMENT IS THE PROPERTY OF FAIRVIEW MICROWAVE CORPORATION. ALL RIGHTS RESERVED.	
CABLE LENGTH (L) TOLERANCES:	L ≤ 12 [305] = +1 [25] / -0	12 [305] < L ≤ 60 [1524] = +2 [51] / -0	60 [1524] < L ≤ 120 [3048] = +4 [102] / -0
	120 [3048] < L ≤ 300 [7620] = +6 [152] / -0	300 [7620] < L = +5%L / -0	
ALL DIMENSIONS SHOWN ARE FOR REFERENCE ONLY.		SCALE	N/A
SIZE	GAGE CODE	DRAWN BY	ITEM NO.
A	3FKRS	VTHANGARAJ	FMCN1909
			REV
			A