

6

5

4

3

2

1

REVISION					
ZONE	REV	DESCRIPTION	DATE	CHANGED BY	APPROVED
	A	INITIAL RELEASE	10/10/2024	KDANG	DWANG

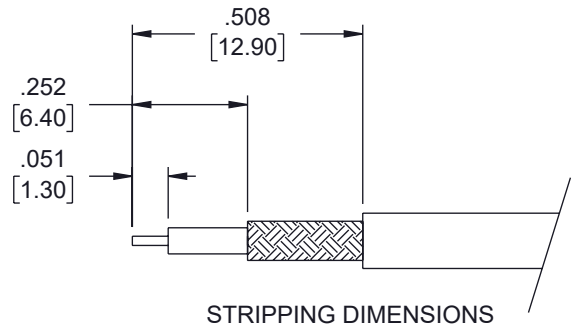
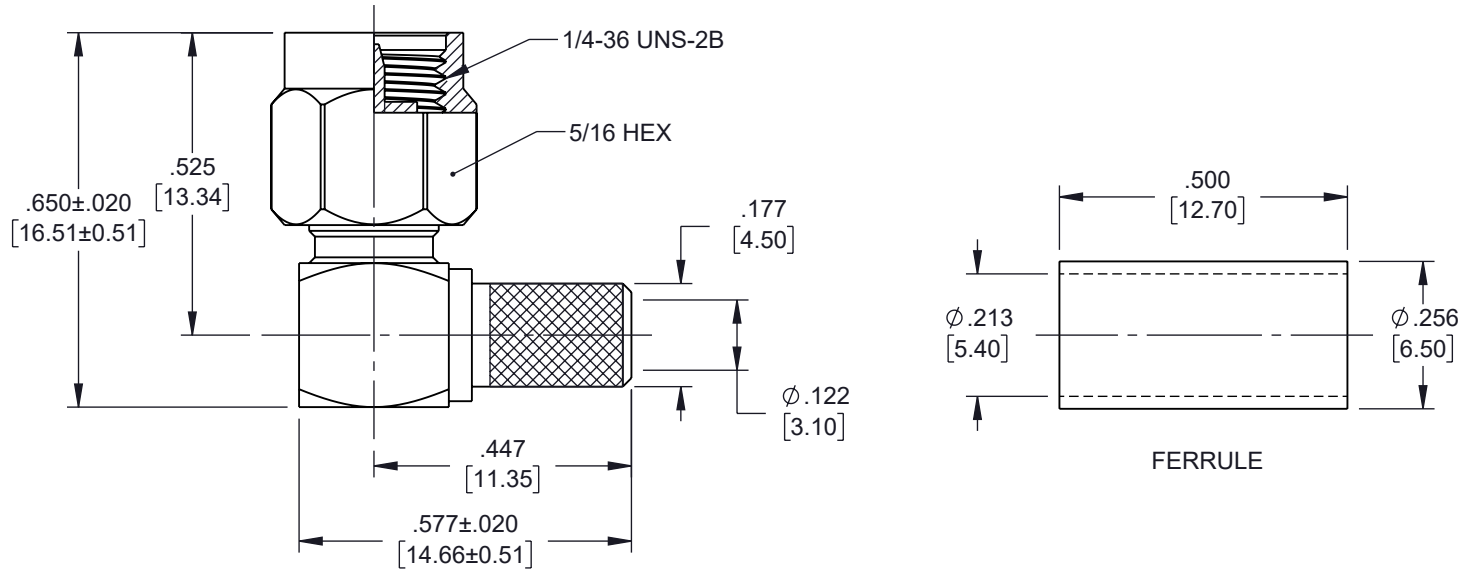

ASSEMBLY PROCEDURES

1. STRIP CABLE AS SHOWN AND SLIDE FERRULE OVER CABLE.
2. INSTALL CABLE INTO THE CONTACT AND SOFT SOLDER FOR CENTER CONDUCTOR & CONTACT IN PLACE.
3. CRIMP FERRULE BY CRIMP TOOL AND PRESS CAP DOWN.

CRIMP SIZE REQUIRED

- FERRULE : .213 [5.41] HEX CRIMP TOOL.
- CONTACT: SOLDER.

THE INFORMATION CONTAINED IN THIS DRAWING IS THE SOLE PROPERTY OF INFINITE ELECTRONICS, INC. ANY REPRODUCTION IN PART OR WHOLE WITHOUT THE WRITTEN PERMISSION OF INFINITE ELECTRONICS, INC. IS PROHIBITED. THESE COMMODITIES, TECHNOLOGY OR SOFTWARE WERE EXPORTED FROM THE UNITED STATES IN ACCORDANCE WITH THE EXPORT ADMINISTRATION REGULATIONS. DIVERSION CONTRARY TO U.S. LAW PROHIBITED.

UNLESS OTHERWISE SPECIFIED  
LEADING DIMENSIONS ARE INCHES  
DIMENSIONS IN [ ] ARE MILLIMETERS

TOLERANCES:

X = ±.2 [5]	FRACTIONS
XX = ±.02 [0.5]	± 1/32
.XXX = ±.005 [0.13]	ANGLES ± 1°

CABLE LENGTH TOLERANCES:

≤12 [305]	= +1 [25] / -0
>12 [305] ≤ 60 [1524]	= +2 [51] / -0
>60 [1524] ≤ 120 [3048]	= +4 [102] / -0
>120 [3048] ≤ 300 [7620]	= +6 [152] / -0
>300 [7620]	= +5% / -0

ALL DIMENSIONS ARE FOR REFERENCE ONLY  
AND SUBJECT TO CHANGE WITHOUT NOTICE  
UN-DIMENSIONED/NON-CRITICAL FEATURES  
MAY VARY IN SIZE AND LOCATION  
COLORS MAY VARY

**Fairview Microwave®**  
an INFINIT@ brand

Website: [www.FairviewMicrowave.com](http://www.FairviewMicrowave.com)  
Phone: 1.800.715.4396 | 1.972.649.6678

INTERPRET ALL DIMENSIONS AND  
TOLERANCES PER ASME Y14.5

SCALE	SHEET
NONE	1 OF 2

DESCRIPTION  
**SMA MALE (PLUG) RIGHT ANGLE CONNECTOR CRIMP/SOLDER  
ATTACHMENT FOR RG58, LMR-195, .195 INCH**

SIZE	CAGE CODE	DRAWN BY	ITEM NO.	REV
A	3FKR5	KDANG	FMCN5271	A

6

5

4

3

2

1

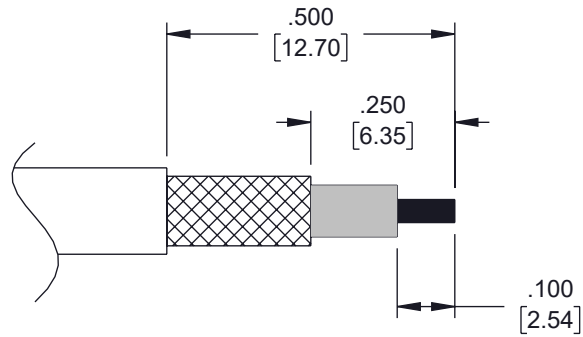

### **STRIPPING DIMENSIONS**

#### ASSEMBLY PROCEDURES

1. STRIP CABLE AS SHOWN & SLIDE FERRULE OVER CABLE.
2. INSTALL CABLE INTO BODY OF CONNECTOR AND SOFT SOLDER CENTER CONDUCTOR IN PLACE.
3. CRIMP FERRULE & PRESS CAP DOWN.

#### CRIMP SIZE REQUIRED

FERRULE: .213" HEX CRIMP TOOL.