

REVISIONS			
REV.	DESCRIPTION	DATE	APPROVED
A	INITIAL RELEASE	8/16/2022	TGALLA

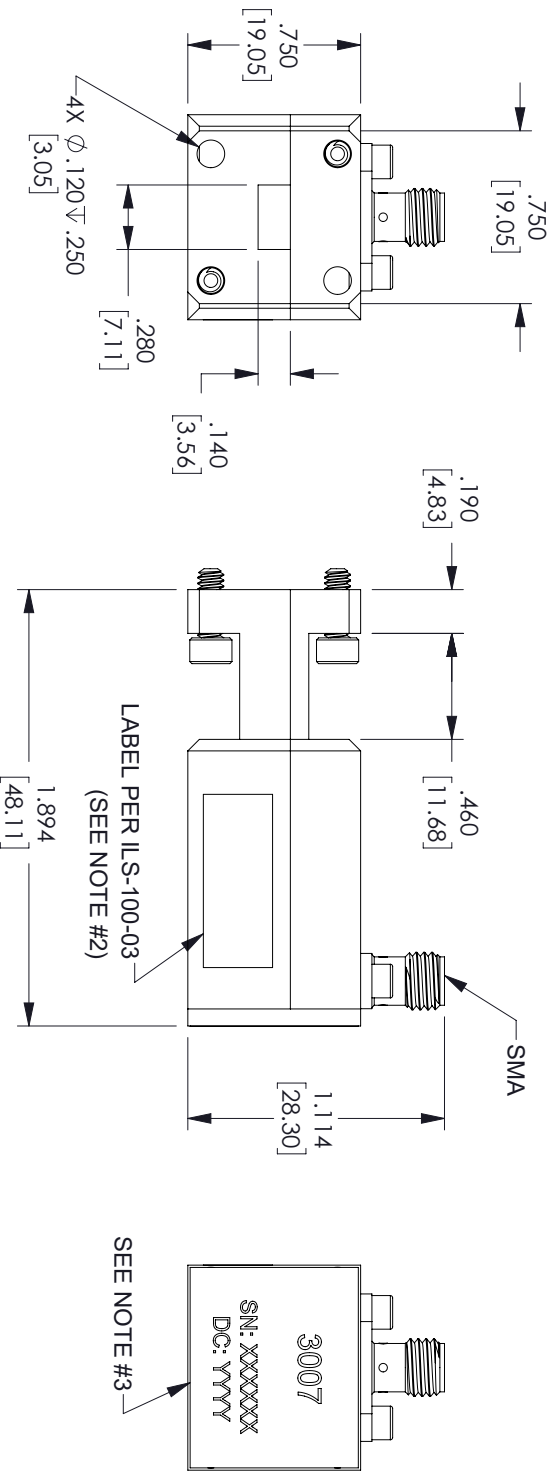

- NOTES:
1. MATERIAL: 6061 T6 ALUMINUM.
 2. LABEL PER ILS-100-03 (FOR INTERNAL REFERENCE ONLY).
 3. LABEL LOCATION FOR REFERENCE ONLY.
 3. SERIAL NUMBER AND DATE CODE EX: SN: 0WZYQD, DC: 2232

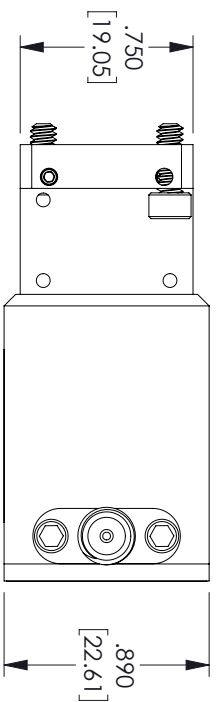
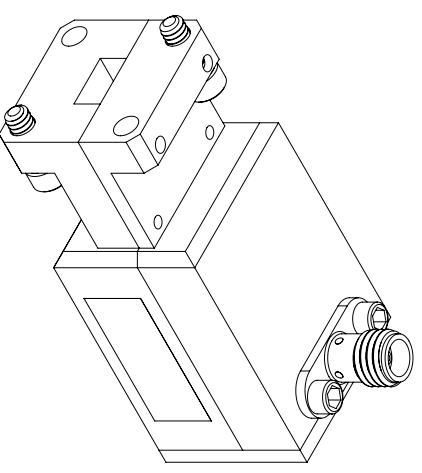

THESE COMMODITIES, TECHNOLOGY OR SOFTWARE WERE EXPORTED FROM THE UNITED STATES IN ACCORDANCE WITH THE EXPORT ADMINISTRATION REGULATIONS, DIVERSION CONTRARY TO U.S. LAW PROHIBITED.



TITLE

UNLESS OTHERWISE SPECIFIED LEADING DIMENSIONS ARE INCHES				THIRD-ANGLE PROJECTION	
DIMENSIONS IN [] ARE MILLIMETERS					
TOLERANCES:				THE INFORMATION AND DESIGN IN THIS DOCUMENT IS THE PROPERTY OF FAIRVIEW MICROWAVE CORPORATION. ALL RIGHTS RESERVED.	
X = ±.2 [5.08]		FRACTIONS ± 1/32		L ≤ 12 [305] = +1 [25] / -0	
XX = ±.02 [51]		± 1/32		12 [305] < L ≤ 60 [1524] = +2 [51] / -0	
XXX = ±.005 [13]		ANGLES ± 1°		60 [1524] < L ≤ 120 [3048] = +4 [102] / -0	
				120 [3048] < L ≤ 300 [7620] = +6 [152] / -0	
				300 [7620] < L = +5%L / -0	
ALL DIMENSIONS SHOWN ARE FOR REFERENCE ONLY.				SCALE	
SIZE	GAGE CODE	DRAWN BY	ITEM NO.	REV	
A	3FKRS	DMAY	FMMT3007	N/A	
				1	1