

REVISIONS			
REV.	DESCRIPTION	DATE	APPROVED
A	PCR FMSW6397	1/6/2020	T.GALLA

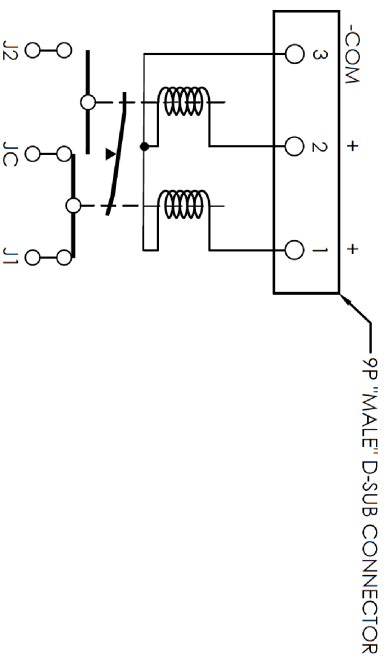

SCHEMATIC

THESE COMMODITIES, TECHNOLOGY OR SOFTWARE WERE EXPORTED FROM THE UNITED STATES IN ACCORDANCE WITH THE EXPORT ADMINISTRATION REGULATIONS, DIVERSION CONTRARY TO U.S. LAW PROHIBITED.

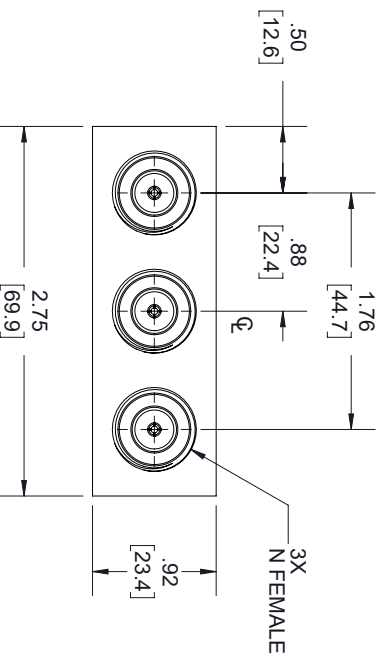
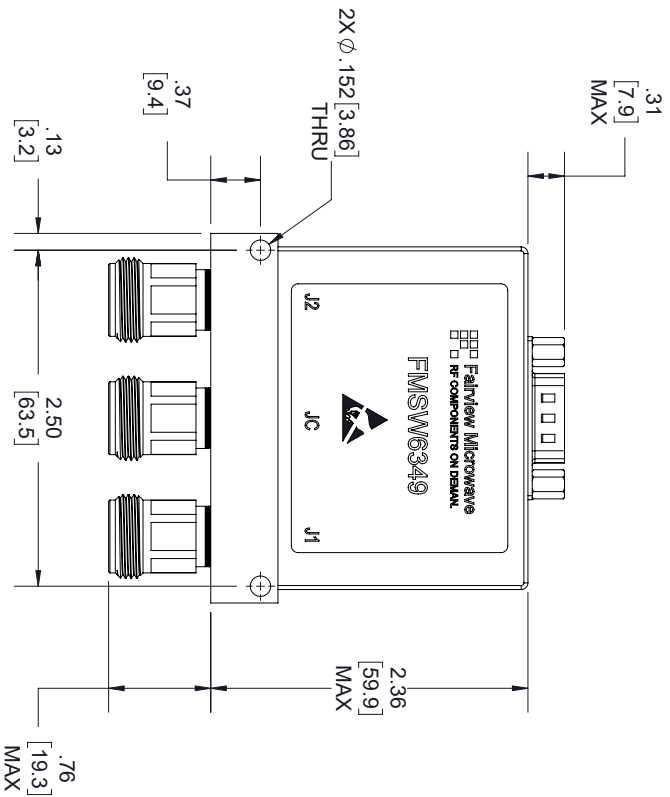
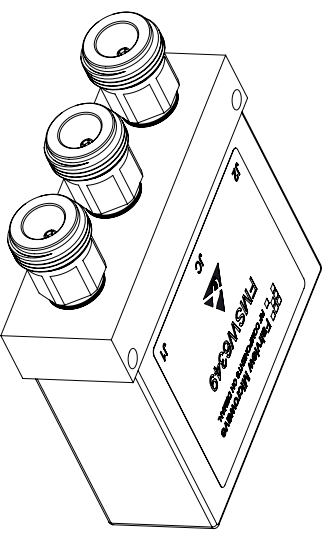
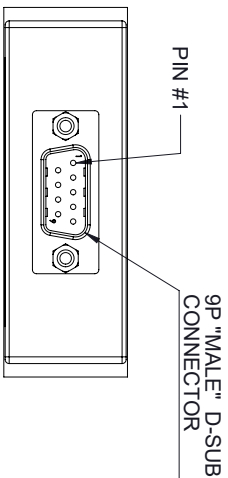

UNLESS OTHERWISE SPECIFIED LEADING DIMENSIONS ARE INCHES
DIMENSIONS IN [] ARE MILLIMETERS

TOLERANCES:

	FRACTIONS	DECIMALS
X = ±.2	[.008]	±.005
XX = ±.02	[.51]	±.012
XXX = ±.005	[.13]	±.005

ANGLES ± 1°

CABLE LENGTH (L) TOLERANCES:

L ≤ 12 [305]	±.1 [25]	/-0
12 [305] < L ≤ 60 [1524]	±.2 [51]	/-0
60 [1524] < L ≤ 120 [3048]	±.4 [102]	/-0
120 [3048] < L ≤ 300 [7620]	±.6 [152]	/-0
300 [7620] < L	±.9 [22.9]	/-0

THIRD-ANGLE PROJECTION

THE INFORMATION AND DESIGN IN THIS DOCUMENT IS THE PROPERTY OF FAIRVIEW MICROWAVE CORPORATION. ALL RIGHTS RESERVED.

SHEET 1 OF 2

ALL DIMENSIONS SHOWN ARE FOR REFERENCE ONLY.

SIZE	GAGE CODE	DRAWN BY	ITEM NO.	SCALE	REV
A	3FKRS	K.DANG	FMSW6349	N/A	A

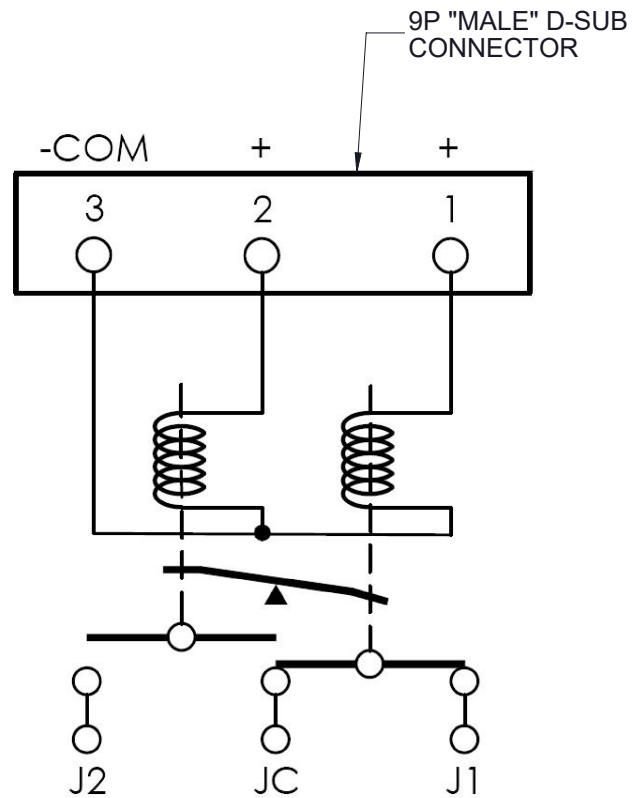

SCHEMATIC SHOWN IN LATCHING POSITION

STANDARD TOLERANCES

.X	±0.2
.XX	±0.01
.XXX	±0.005

*STANDARD TOLERANCES APPLY ONLY TO DIMENSIONS IN INCHES



Pasternack Enterprises, Inc.
P.O. Box 16759 | Irvine | CA | 92623

Phone: (949) 261-1920 | Fax: (949) 261-7451

Website: www.pasternack.com | E-Mail: sales@pasternack.com

DWG TITLE

PE71S6349

NOTES:

1. UNLESS OTHERWISE SPECIFIED ALL DIMENSIONS ARE NOMINAL.
2. ALL SPECIFICATIONS ARE SUBJECT TO CHANGE WITHOUT NOTICE AT ANY TIME.
3. DIMENSIONS ARE IN INCHES [mm].

CAGE CODE 53919

CAD FILE 112117

SCALE N/A

SIZE A

7361