

REVISIONS			
REV.	DESCRIPTION	DATE	APPROVED
A	INITIAL RELEASE	05/19/2022	T.GALLA

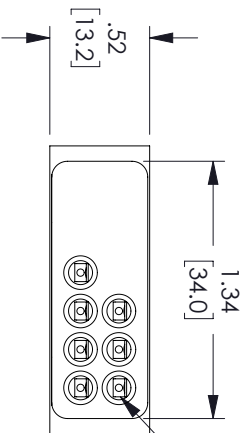

7X SOLDER TERMINALS
SOLDER WISE USING SN96,
MAXIMUM TEMP 250 °C FOR
NO MORE THAN 5 SEC.

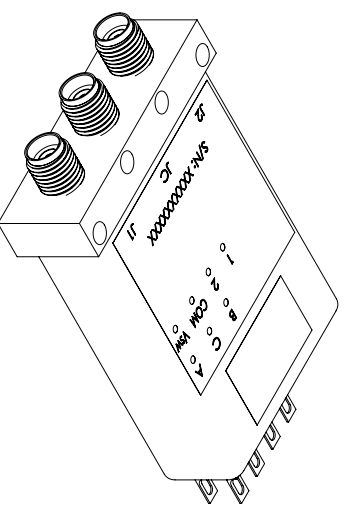
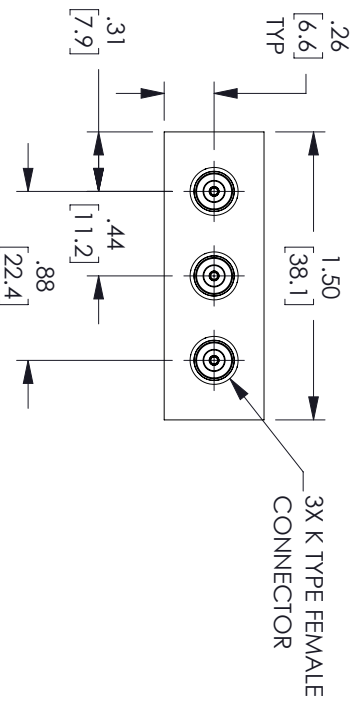
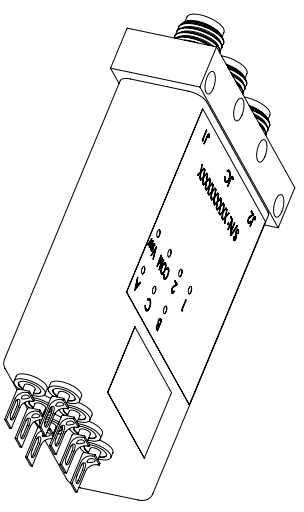
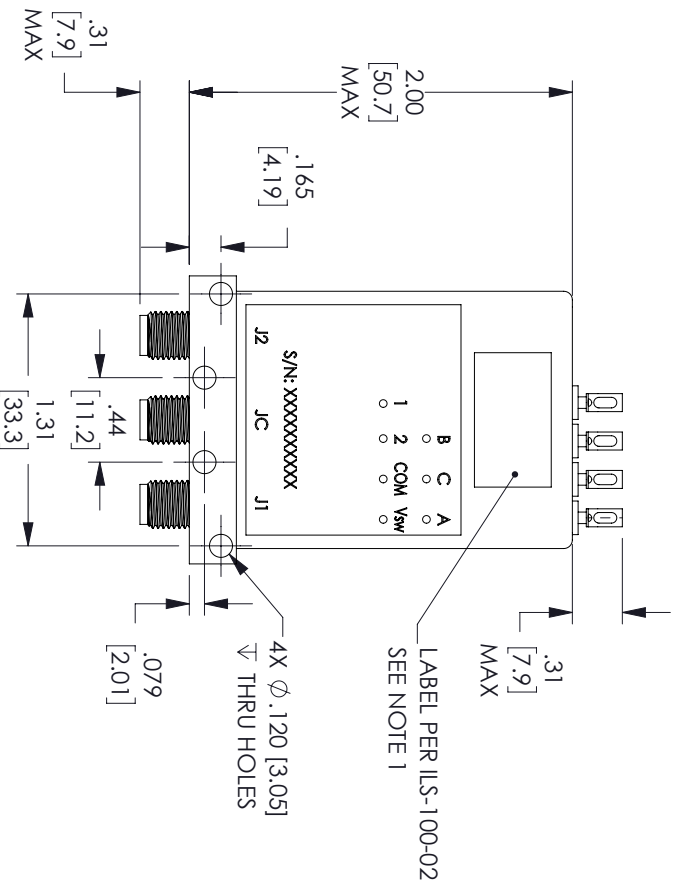

- NOTES:
- LABEL PER ILS-100-02. FOR INTERNAL REFERENCE ONLY.
LABEL LOCATION FOR REFERENCE ONLY.

THESE COMMODITIES, TECHNOLOGY OR SOFTWARE WERE EXPORTED FROM THE UNITED STATES IN ACCORDANCE WITH THE EXPORT ADMINISTRATION REGULATIONS, DIVERSION CONTRARY TO U.S. LAW PROHIBITED.



TITLE

UNLESS OTHERWISE SPECIFIED LEADING DIMENSIONS ARE INCHES DIMENSIONS IN [] ARE MILLIMETERS				THIRD-ANGLE PROJECTION	
TOLERANCES:				THE INFORMATION AND DESIGN IN THIS DOCUMENT IS THE PROPERTY OF FAIRVIEW MICROWAVE CORPORATION. ALL RIGHTS RESERVED.	
CABLE LENGTH (L) TOLERANCES:		L ≤ 12 [305] = +1 [25] / -0		SCALE	
X = ±.2 [5.08]		FRACTIONS		12 [305] < L ≤ 60 [1524] = +2 [51] / -0	
XX = ±.02 [.51]		± 1/32		60 [1524] < L ≤ 120 [3048] = +4 [102] / -0	
XXX = ±.005 [.13]		ANGLES ± 1°		120 [3048] < L ≤ 300 [7620] = +6 [152] / -0	
				300 [7620] < L = +5% / -0	
SIZE	GAGE CODE	DRAWN BY	ITEM NO.	SCALE	REV
A	3FKRS	KGLEBOVA	FMSW6481	N/A	A