

UOKWUWUPU			
UOXE	WUWUWUWUP	UWUO	WUWUWUXOO
CE	WUWUWUWUWUWU	FUWU WUWU	WUWUWUWU

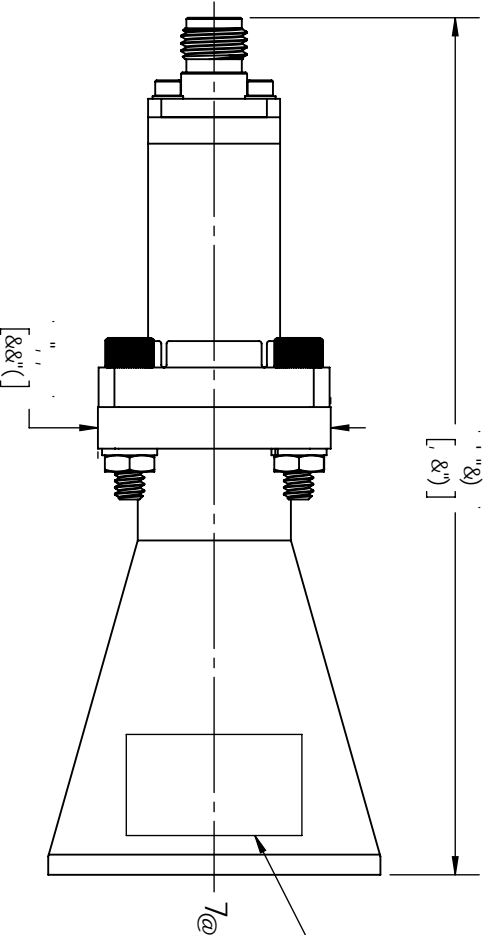

69D9F WUWUWU
F99B C H WU

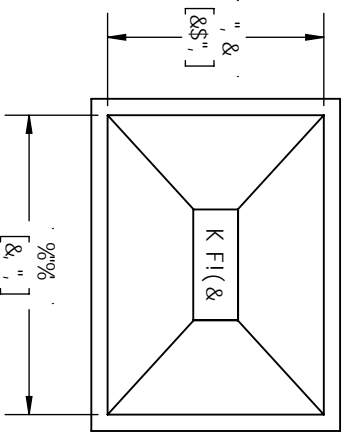
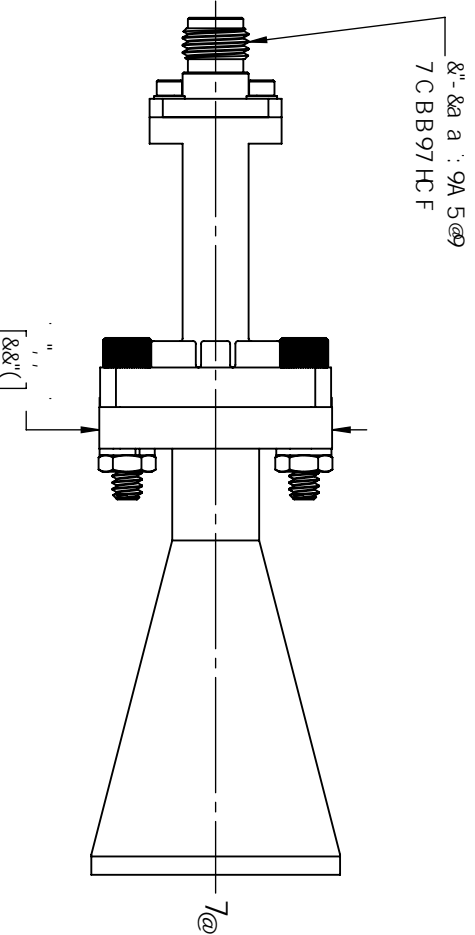

BCHRG
 % (69D9F WUWUWU) F I C F B H F B 5 @ F 9 9 F 9 B 7 9 C B @ M
 ... (69WU 7 5 H C B : C F F 9 9 F 9 B 7 9 C B @ M

WUWUWUWU WUWUWUWU WUWUWUWU WUWUWUWU WUWUWUWU WUWUWUWU WUWUWUWU WUWUWUWU WUWUWUWU WUWUWUWU WUWUWUWU WUWUWUWU



HH@9
 VP
 WUWUWUWU

WUWUWUWU WUWUWUWU WUWUWUWU WUWUWUWU WUWUWUWU WUWUWUWU WUWUWUWU WUWUWUWU WUWUWUWU WUWUWUWU WUWUWUWU WUWUWUWU			
UWU	WUWUWUWUWU	WUWU WUWU	WUWUWUWU WUWUWUWU
CE	WUWUWU	WUWU WUWU	WUWU WUWU
WUWUWUWU WUWUWUWU WUWUWUWU WUWUWUWU WUWUWUWU WUWUWUWU WUWUWUWU WUWUWUWU WUWUWUWU WUWUWUWU WUWUWUWU WUWUWUWU			
WUWU	WUWUWUWU WUWUWUWU	WUWU WUWU	WUWU WUWU
CE	WUWUWU	WUWU WUWU	WUWU WUWU
WUWUWUWU WUWUWUWU WUWUWUWU WUWUWUWU WUWUWUWU WUWUWUWU WUWUWUWU WUWUWUWU WUWUWUWU WUWUWUWU WUWUWUWU WUWUWUWU			
UWUWU	WUWUWU WUWUWU	WUWU WUWU	WUWU WUWU
CE	WUWUWU	WUWU WUWU	WUWU WUWU