

ITEM NO.	DESCRIPTION	QTY.
1	GASKET	1
2	8-32 X 3/8, SCREW	4
3	#8 SPLIT LOCK WASHER	4

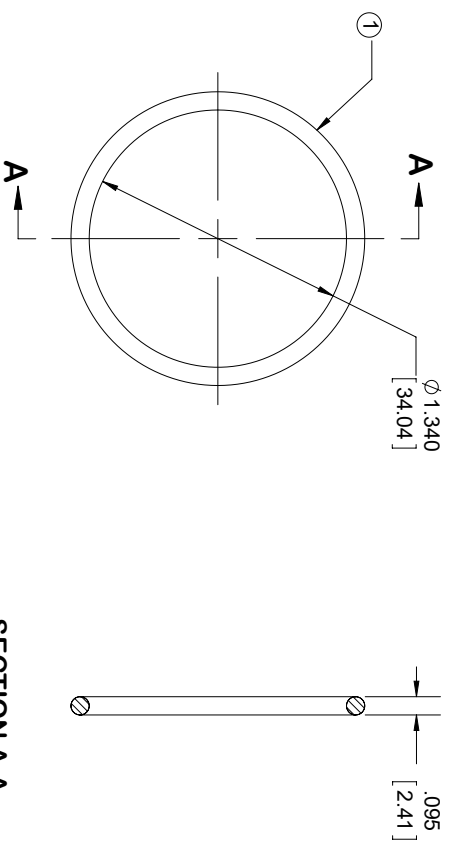

SECTION A-A

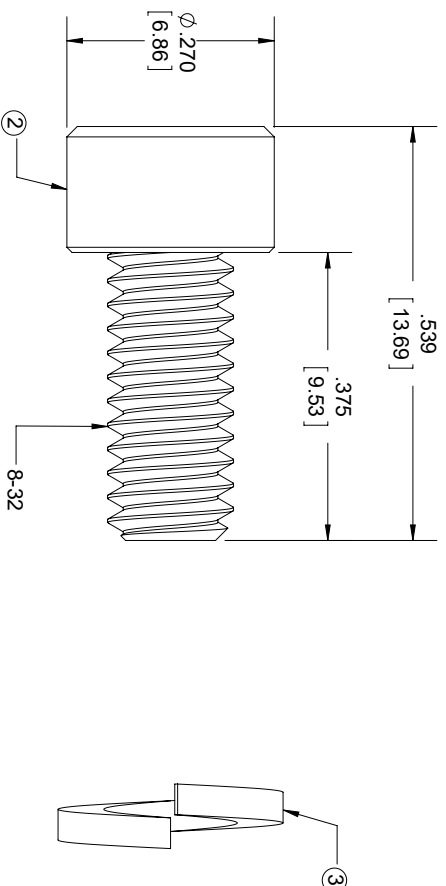

STANDARD TOLERANCES	
.X	±0.2
.XX	±0.01
.XXX	±0.005

*STANDARD TOLERANCES APPLY ONLY TO DIMENSIONS IN INCHES

FAIRVIEW MICROWAVE INC.

ALLEN, TX 75013 WWW.FAIRVIEWMICROWAVE.COM

NOTES:
 1. UNLESS OTHERWISE SPECIFIED ALL DIMENSIONS ARE NOMINAL.
 2. ALL SPECIFICATIONS ARE SUBJECT TO CHANGE WITHOUT NOTICE AT ANY TIME.
 3. DIMENSIONS ARE IN INCHES [mm].

TITLE		DWG NO		CAGE CODE	
		FMW/GK1005		3FKR5	
CAD FILE	073117	SHEET	1 OF 1	SCALE	N/A
				SIZE	A
					9999