

REVISIONS			
REV.	DESCRIPTION	DATE	APPROVED
B	SC6029 2022053	07/27/2022	AMARG

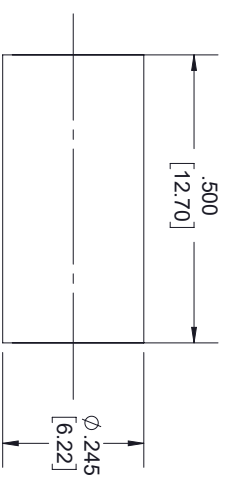

CONTACT

FERRULE DIMENSION

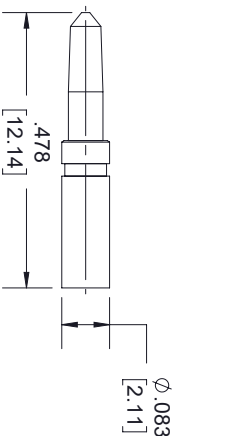
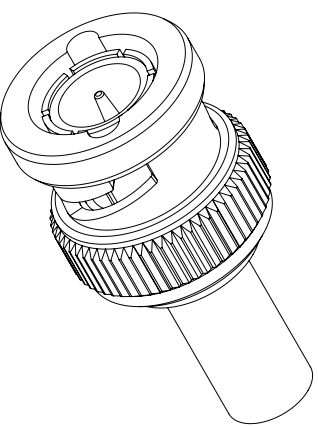
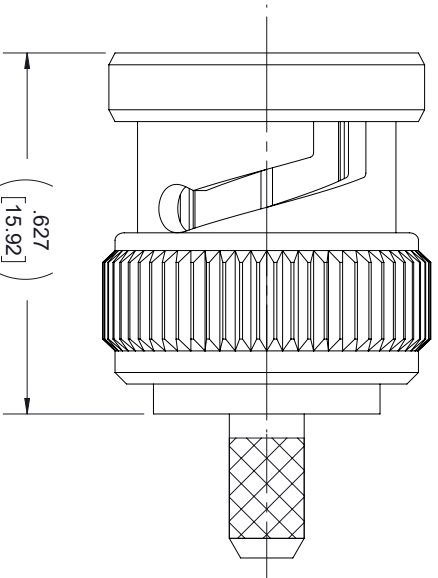
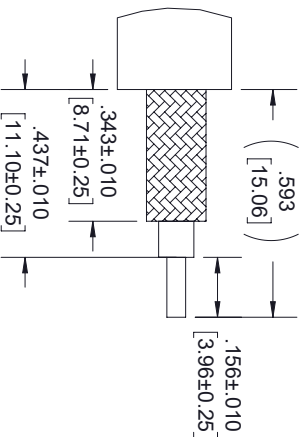

STRIPPING DIMENSIONS

CRIMP SIZE REQUIRED

CONTACT: .068" HEX CRIMP TOOL

FERRULE: .213" HEX CRIMP TOOL

THESE COMMODITIES, TECHNOLOGY OR SOFTWARE WERE EXPORTED FROM THE UNITED STATES IN ACCORDANCE WITH THE EXPORT ADMINISTRATION REGULATIONS, DIVERSION CONTRARY TO U.S. LAW PROHIBITED.



TITLE

UNLESS OTHERWISE SPECIFIED LEADING DIMENSIONS ARE INCHES DIMENSIONS IN [] ARE MILLIMETERS				THIRD-ANGLE PROJECTION	
TOLERANCES:				THE INFORMATION AND DESIGN IN THIS DOCUMENT IS THE PROPERTY OF FAIRVIEW MICROWAVE CORPORATION. ALL RIGHTS RESERVED.	
CABLE LENGTH (L) TOLERANCES:		FRACTIONS		SHEET 1 OF 1	
L ± 1/2 (806) = +1 (25) / -0		XX ± 0.02 [.51]		SCALE N/A	
L ≤ 60 [1524] = +2 (51) / -0		XXX ± 0.005 [.13]		REV B	
60 [1524] < L ≤ 120 [3048] = +4 (102) / -0		ANGLES ± 1°			
120 [3048] < L ≤ 300 [7620] = +6 (152) / -0					
300 [7620] < L = +5% / -0					
ALL DIMENSIONS SHOWN ARE FOR REFERENCE ONLY.					
SIZE	GAGE CODE	DRAWN BY	ITEM NO.	REV	
A	3FKRS	WZHANG	SC6029		