

REVISIONS			
REV.	DESCRIPTION	DATE	APPROVED
A	FOR SCT1635-SMA	12/31/2019	S ELLIS

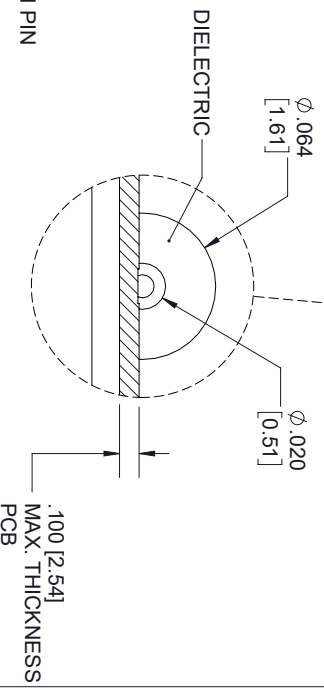

THESE COMMODITIES, TECHNOLOGY OR SOFTWARE WERE EXPORTED FROM THE UNITED STATES IN ACCORDANCE WITH THE EXPORT ADMINISTRATION REGULATIONS, DIVERSION CONTRARY TO U.S. LAW PROHIBITED.

Fairview Microwave[™]

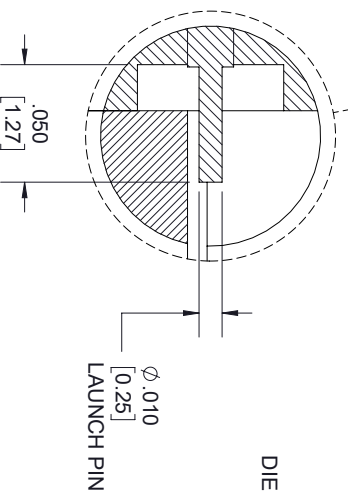
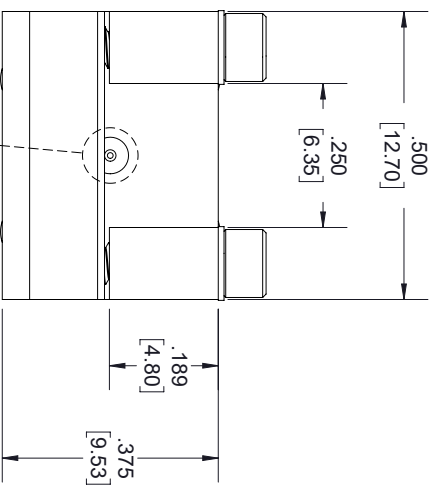
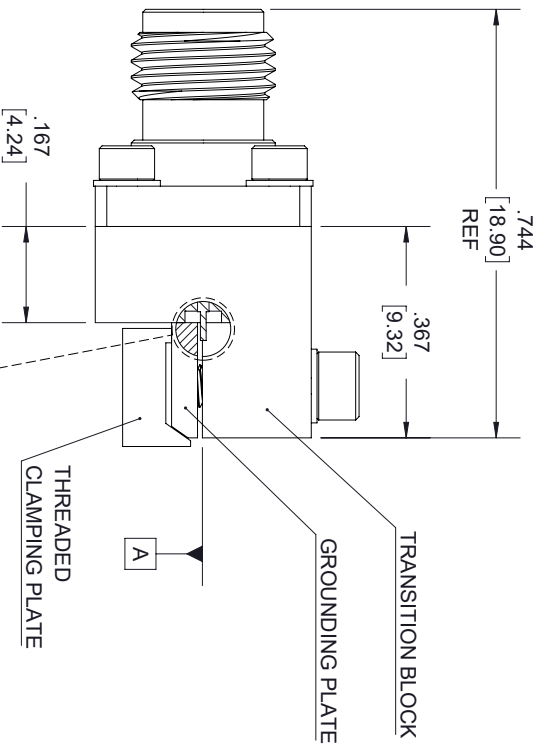
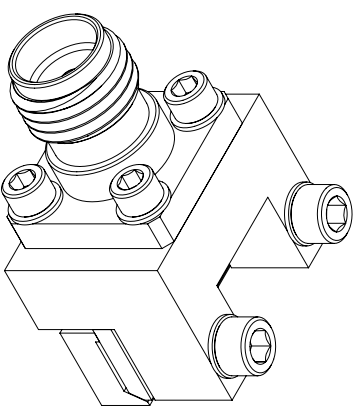
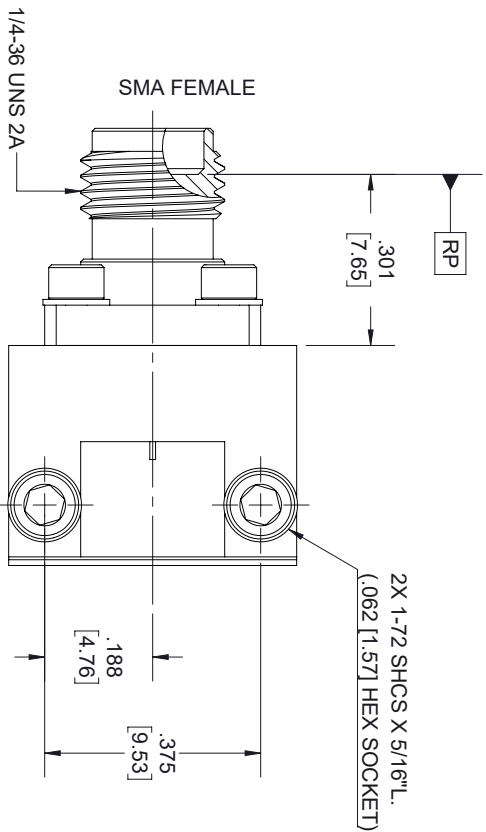

an INFINITT® brand

TITLE

UNLESS OTHERWISE SPECIFIED LEADING DIMENSIONS ARE INCHES
DIMENSIONS IN [] ARE MILLIMETERS

TOLERANCES:

CABLE LENGTH (L) TOLERANCES:

THIRD-ANGLE PROJECTION

X = ±.2 [5.08] FRACTIONS
XX = ±.02 [.51] ±.1/32
XXX = ±.005 [.13] ANGLES ± 1°

L ≤ 12 [305] = +1 [25] / -0
12 [305] < L ≤ 60 [1524] = +2 [51] / -0
60 [1524] < L ≤ 120 [3048] = +4 [102] / -0
120 [3048] < L ≤ 300 [7620] = +6 [152] / -0
300 [7620] < L = +5% / -0

THE INFORMATION AND DESIGN IN THIS DOCUMENT IS THE PROPERTY OF FAIRVIEW MICROWAVE CORPORATION. ALL RIGHTS RESERVED.

SHEET 1 OF 1

ALL DIMENSIONS SHOWN ARE FOR REFERENCE ONLY.

SCALE N/A

SIZE	DRAWN BY	ITEM NO.	REV
A	K. Dang	SCT1635-SMA	A

SIZE	GAGE CODE	DRAWN BY	ITEM NO.	REV
A	3FKR5	K. Dang	SCT1635-SMA	A