

**STRIPPING DIMENSIONS**

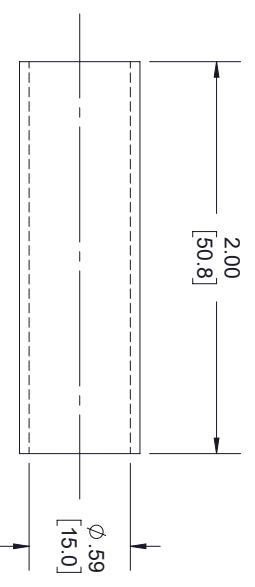

**SHRINK TUBE**

- NOTES:
1. CABLE ATTACHMENT:
    - OUTER: SOLDER.
    - INNER: SOLDER.

STANDARD TOLERANCES  
 .X ±0.2  
 .XX ±0.01  
 .XXX ±0.005

\*STANDARD TOLERANCES APPLY ONLY TO DIMENSIONS IN INCHES

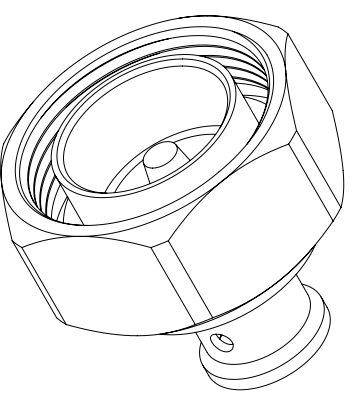

NOTES:  
 1. UNLESS OTHERWISE SPECIFIED ALL DIMENSIONS ARE NOMINAL.  
 2. ALL SPECIFICATIONS ARE SUBJECT TO CHANGE WITHOUT NOTICE AT ANY TIME.  
 3. DIMENSIONS ARE IN INCHES [mm].

TITLE		DWG NO		CAGE CODE	
		TC-375-716M-LP		3FKR5	
CAD FILE	05/29/19	SHEET	1 OF 1	SCALE	N/A
				SIZE	A
					7361