

6

5

4

3

2

1

REVISION					
ZONE	REV.	DESCRIPTION	DATE	CHANGED BY	APPROVED BY
	A	INITIAL RELEASE	09/08/2023	BPUCHASKI	GUTTADAURO

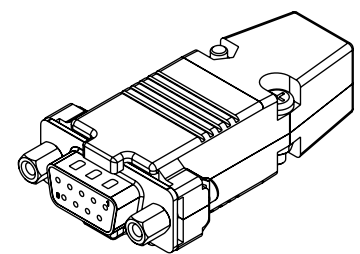
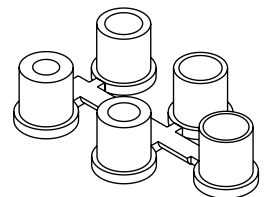
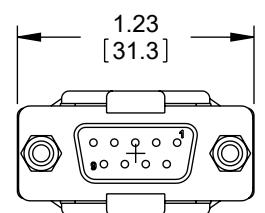
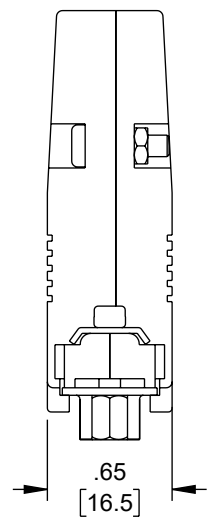
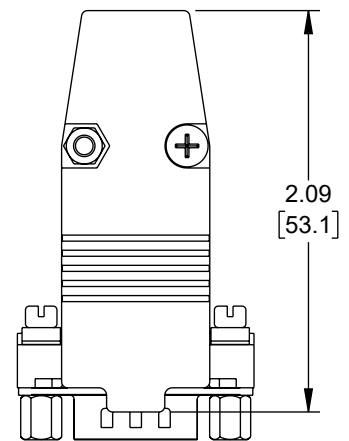
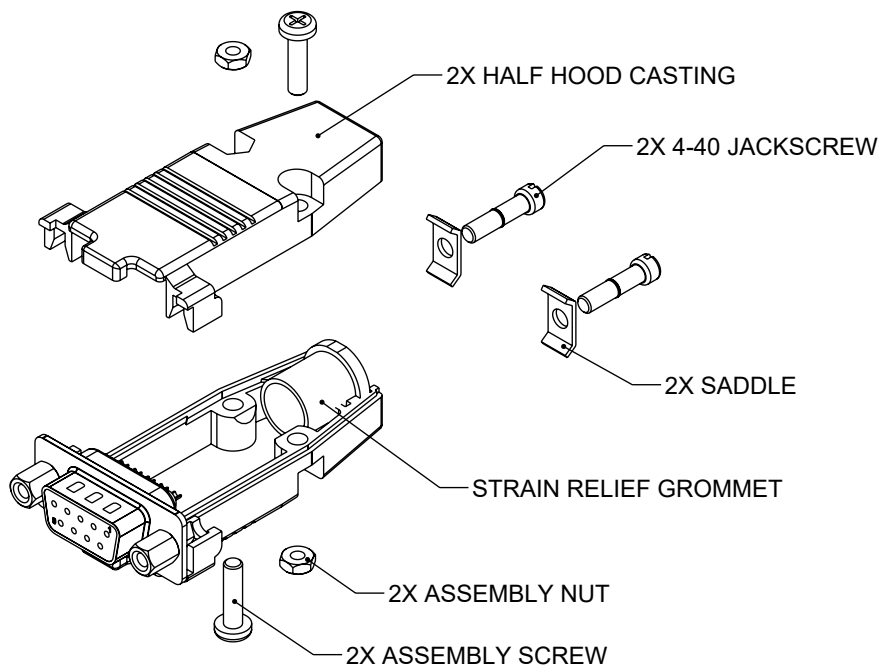

**NOTES:**

**MATERIAL:**

HOOD: DIE-CAST ZINC ALLOY  
 JACKSCREWS: STEEL OR STAINLESS STEEL  
 SADDLE & ASSEMBLY HARDWARE: STEEL OR STAINLESS STEEL  
 STRAIN RELIEF GROMMETS: PVC BLACK

**FINISH:**

HOOD: NICKEL PLATED, MATTE FINISH ON MAJOR SURFACES  
 JACKSCREWS: NICKEL PLATED; PASSIVATE IS OPTION FOR STAINLESS STEEL  
 SADDLE & ASSEMBLY HARDWARE: NICKEL PLATED; PASSIVATE IS OPTION FOR STAINLESS STEEL

**MISCELLANEOUS:**

INTENDED FOR USE WITH 9-PIN STANDARD AND 15-PIN HIGH DENSITY D-SUBMINIATURE CONNECTORS.  
 SUPPLIED WITH 5 STRAIN RELIEF GROMMETS FOR CABLES HAVING DIAMETERS RANGING FROM .190 TO .335 INCH.

**REGULATORY COMPLIANCE:**

EU RoHS DIRECTIVE (MOST RECENT RELEASED VERSION)

THE INFORMATION CONTAINED IN THIS DRAWING IS THE SOLE PROPERTY OF INFINITE ELECTRONICS, INC. ANY REPRODUCTION IN PART OR WHOLE WITHOUT THE WRITTEN PERMISSION OF INFINITE ELECTRONICS, INC. IS PROHIBITED. THESE COMMODITIES, TECHNOLOGY OR SOFTWARE WERE EXPORTED FROM THE UNITED STATES IN ACCORDANCE WITH THE EXPORT ADMINISTRATION REGULATIONS. DIVERSION CONTRARY TO U.S. LAW PROHIBITED.

UNLESS OTHERWISE SPECIFIED LEADING DIMENSIONS ARE INCHES DIMENSIONS IN [ ] ARE MILLIMETERS	
TOLERANCES:	
.X = ±.2 [5]	FRACTIONS ± 1/32
.XX = ±.02 [0.5]	ANGLES ± 1°
.XXX = ±.005 [0.13]	
CABLE LENGTH TOLERANCES:	
≤12 [305]	= +1 [25] / -0
>12 [305] ≤ 60 [1524]	= +2 [51] / -0
>60 [1524] ≤ 120 [3048]	= +4 [102] / -0
>120 [3048] ≤ 300 [7620]	= +6 [152] / -0
>300 [7620]	= +5% / -0
ALL DIMENSIONS ARE FOR REFERENCE ONLY AND SUBJECT TO CHANGE WITHOUT NOTICE. UN-DIMENSIONED/NON-CRITICAL FEATURES MAY VARY IN SIZE AND LOCATION. COLORS MAY VARY.	

<p><b>Fairview Microwave®</b> an INFINIT® brand</p>		<p>INTERPRET ALL DIMENSIONS AND TOLERANCES PER ASME Y14.5</p>	
<p>Website: <a href="http://www.FairviewMicrowave.com">www.FairviewMicrowave.com</a>          Phone: 1.800.715.4396   1.972.649.6678</p>		SCALE	SHEET
DESCRIPTION		NONE	1 OF 1
<b>ASSEMBLED D-SUB HOOD KIT, DB9/HD26 METAL</b>			
SIZE	CAGE CODE	DRAWN BY	ITEM NO.
A	3FKR5	BPUCHASKI	FM1034
			REV
			A

6

5

4

3

2

1