

6

5

4

3

2

1

REVISION					
ZONE	REV.	DESCRIPTION	DATE	CHANGED BY	APPROVED BY
	A	INITIAL RELEASE	09/08/2023	BPUCHASKI	GUTTADAURO

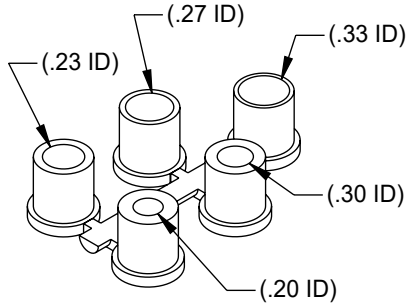
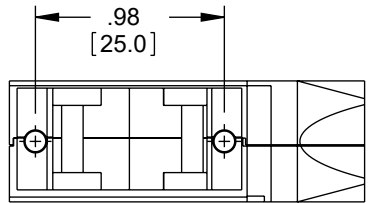
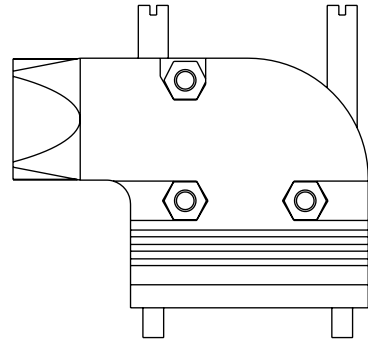
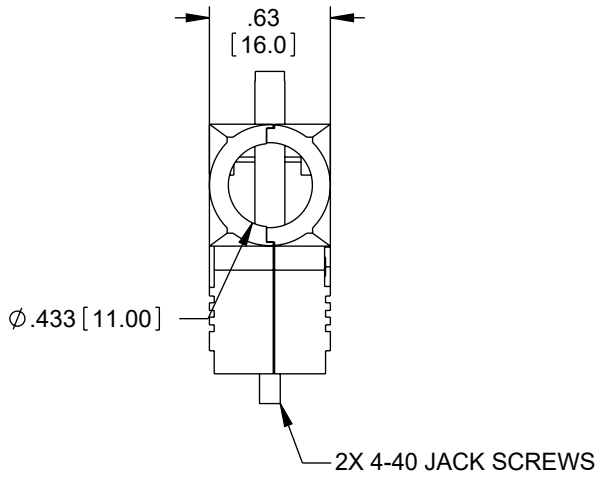
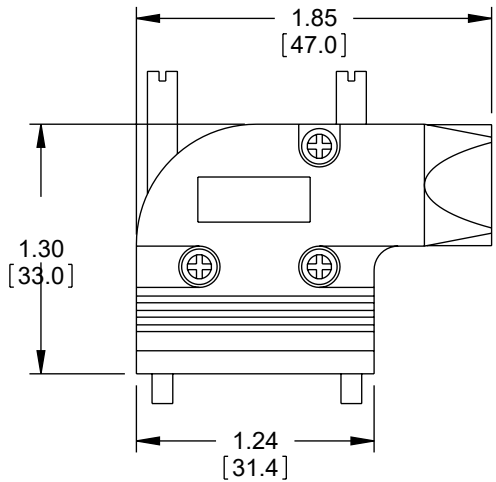

GROMMETS AS SUPPLIED

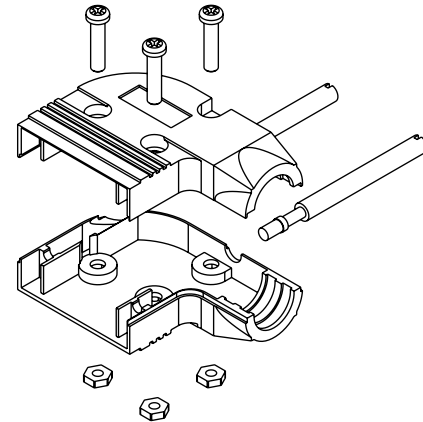

NOTES:

MATERIALS:
 HOOD: DIE-CAST ZINC ALLOY
 THUMBSCREW: STEEL
 ASSEMBLY HARDWARE: STEEL
 STRAIN RELIEF GROMMETS: PVC, BLACK

FINISH:
 HOOD: NICKEL PLATED, MATTE FINISH ON MAJOR SURFACES
 THUMBSCREW: NICKEL PLATED
 ASSEMBLY HARDWARE: NICKEL PLATED

MISCELLANEOUS:
 INTENDED FOR USE WITH 9 PIN STANDARD AND 15 PIN HIGH DENSITY D-SUBMINIATURE CONNECTORS.
 SUPPLIED WITH 5 STRAIN RELIEF GROMMETS FOR CABLING HAVING DIAMETERS RANGING FROM .190 TO .335 INCH.
 ALL DIMENSIONS ARE FOR REFERENCE.

REGULATORY COMPLIANCE:
 EU RoHS DIRECTIVE (MOST RECENT RELEASED VERSION)

THE INFORMATION CONTAINED IN THIS DRAWING IS THE SOLE PROPERTY OF INFINITE ELECTRONICS, INC. ANY REPRODUCTION IN PART OR WHOLE WITHOUT THE WRITTEN PERMISSION OF INFINITE ELECTRONICS, INC. IS PROHIBITED. THESE COMMODITIES, TECHNOLOGY OR SOFTWARE WERE EXPORTED FROM THE UNITED STATES IN ACCORDANCE WITH THE EXPORT ADMINISTRATION REGULATIONS. DIVERSION CONTRARY TO U.S. LAW PROHIBITED.

UNLESS OTHERWISE SPECIFIED LEADING DIMENSIONS ARE INCHES DIMENSIONS IN [] ARE MILLIMETERS

TOLERANCES:

.X = ±.2 [5]	FRACTIONS ± 1/32
.XX = ±.02 [0.5]	ANGLES ± 1°
.XXX = ±.005 [0.13]	

CABLE LENGTH TOLERANCES:

≤12 [305]	= +1 [25] / -0
>12 [305] ≤ 60 [1524]	= +2 [51] / -0
>60 [1524] ≤ 120 [3048]	= +4 [102] / -0
>120 [3048] ≤ 300 [7620]	= +6 [152] / -0
>300 [7620]	= +5% / -0

ALL DIMENSIONS ARE FOR REFERENCE ONLY AND SUBJECT TO CHANGE WITHOUT NOTICE. UN-DIMENSIONED/NON-CRITICAL FEATURES MAY VARY IN SIZE AND LOCATION COLORS MAY VARY

Fairview Microwave®
 an INFINIT® brand

Website: www.FairviewMicrowave.com
 Phone: 1.800.715.4396 | 1.972.649.6678

INTERPRET ALL DIMENSIONS AND TOLERANCES PER ASME Y14.5	
SCALE NONE	SHEET 1 OF 1

DESCRIPTION
RIGHT ANGLE ASSEMBLED D-SUB HOOD KIT, DB9/HD15 METAL

SIZE A	CAGE CODE 3FKR5	DRAWN BY BPUCHASKI	ITEM NO. FM1048	REV A
-----------	--------------------	-----------------------	--------------------	----------

6

5

4

3

2

1