

30 MHz to 2.7 GHz, SMA, GaN Bi-Directional Amplifier, High Power, 8W Psat, 36dB Tx Gain, 1 microsec speed, Manual T/R Control

The FM15B5003 is a high-power Bi-Directional Amplifier that utilizes GaN technology and covers a broad frequency band from 30 MHz to 2700 MHz. This amplifier produces 8W of Peak Tx Power while efficiently consuming only 24W of DC power. The design can also generate 2W of linear 16 QAM power with < 9% EVM. High efficiency operation in combination with a very small package size that weighs only 4 oz makes it ideal for SWaP friendly commercial and military software defined radio (SDR) applications. The model offers up to 36 dB of small signal gain and operates over a wide DC input range from +12 Vdc to +30 VDC. Manual Tx and Rx switching (TTL) time is 1 μ sec typical. The rugged package design operates over -40°C to +85°C, supports SMA-Female RF Connectors, and is guaranteed to meet MIL-STD-810 environmental conditions for Shock and Vibration, in addition to exposure to 95% humidity and up to 30,000 ft Altitude. An available Cable Assembly with DC Socket connector is available (FMAMJ000) as an accessory specific to this model. See illustration below.

Electrical Specifications (TA = +25°C, DC Voltage = 30Volts DC Current = 1.4A)

Transmit

Description	Min	Typ	Max	Unit
Frequency Range	0.03		2.7	GHz
Psat Output Power		39		Watts
Gain		36		dB
Gain Flatness		±3		dB
Input Return Loss	-12	-15		dB
Operating DC Voltage	12		30	Volts
Current Draw		1.4		A
Switching Time		1	2	uSec

Receive

Description	Min	Typ	Max	Unit
1 dB Compression Point		+15		dBm
Gain		30		dB
Gain Flatness		±2		dB
Input Return Loss	-10	-12		dB
Noise Figure		2		dB
Current Draw		200	0	mA



Features:

- 8W Bi-Directional Amplifier
- Broadband GaN Design Covers 30 to 2700 MHz
- Highly Efficient Design and Small Package Size
- Produces over 8W of Peak Tx Power
- Small Signal Gain: 30dB (Rx) and 36 dB (Tx)
- Produces 2W of Linear 16 QAM Power with < 9% EVM
- Ideal for SWaP friendly Commercial and Military SDR
- Wide DC input Range +11 Vdc to +28 Vdc
- Operating Temperature Range: -40°C to +85°C
- High Speed On/Off Control
- Over-Temperature Protection
- Temperature Monitor Output Pin
- Manual Tx/Rx Switching Time (TTL): 1 μ sec Typical
- Input/Output RF Connectors: SMA-Female
- 50 Ohms Input and Output Matched
- Weight: 4 oz
- Available Cable Assembly with DC Socket Connector (FMAMJ000)

Applications:

- SWaP Friendly Commercial and Military Software Defined Radio(SDR)
- L-Band Military Radio
- Communications Systems
- High Gain Driver Power Amplifier
- High Gain Output Power Amplifier

Fairview Microwave
 301 Leora Ln., Suite 100
 Lewisville, TX 75056
 Tel: 1-800-715-4396 / (972) 649-6678
 Fax: (972) 649-6689
www.fairviewmicrowave.com
sales@fairviewmicrowave.com

Mechanical Specifications

Size

Length	3.25 in [82.55 mm]
Width	2.42 in [61.47 mm]
Height	0.54 in [13.72 mm]
Weight	0.283 lbs [128.37 g]
RF Connector (Input)	SMA Female
RF Connector (Output)	SMA Female
DC Connector	8-Pin Rectangular Male
Cooling	Baseplate Conduction-Optional Heatsink Available

Environmental Specifications

Temperature

Operating Range	-40 to +85 deg C
Storage Range	-60 to +150 deg C
Humidity	95%
Shock	MIL-STD-810
Vibration	MIL-STD-810
Altitude	0 to 30,000 ft

Compliance Certifications (see [product page](#) for current document)

Plotted and Other Data

Notes:

- Values at +25 °C, sea level

Amplifier Power-up Precautions

- 1.) Confirm that proper ESD precautions and controls are always in place before handling any Amplifier module.
- 2.) Confirm adequate thermal management is in place to effectively dissipate heat away from the Amplifier package. The Amplifier operational baseplate temperature must be within the operational temperature range stated in the Amplifier datasheet. Depending on the design and thermal requirements, using a heatsink with cooling fan is always recommended for safe reliable operation. A heat sink without a cooling fan may also be used. Damage caused from overheating will void the warranty.
- 3.) Confirm adequate system grounding is established. The DC power supply and Amplifier must have a common ground in order to operate properly.
- 4.) Power Amplifiers may require additional DC Current when initially powered-up. Depending on the design, the input current draw could range from an additional 10% to 100% above the maximum rated DC current of the Amplifier. This varies based on product part number.
- 5.) Confirm the DC power supply, if limited, is set to allow for additional start-up current that's rated for the Power Amplifier.
- 6.) Confirm the system is designed and calibrated for 50 ohms. Any impedance mismatch may cause performance issues.
- 7.) Perform a CALIBRATION (if required) with the loads before connecting the Amplifier to the Network Analyzer to ensure proper performance.
- 8.) Use a fixed attenuator between the signal source and input port of the Amplifier to optimize the input VSWR match.
- 9.) Confirm the input power level at the input port of the amplifier does not exceed the maximum rated limit for input power (as stated in the Amplifier datasheet).
 P_{in} for Small Signal Gain = P1dB-SSG-10 dB
 P_{in} for P1dB = P1dB-SSG+1 dB
- 10.) Confirm the Network Analyzer is always connected to the Amplifier first before DC power is applied to the Amplifier.
- 11.) As long as the input and output ports of the amplifier are connected to a 50Ohm load and RF signal power is applied, the Amplifier can be powered up with DC voltage.
- 12.) Confirm the Amplifier output load is matched for a 50 Ohm impedance and will not exceed the maximum rated VSWR or Return Loss limit for the Amplifier. Exceeding the maximum rated VSWR or Return Loss limit will result in reflected signal power that could damage the Amplifier and void the warranty.
- 13.) **Power Amplifier connected to an Antenna for signal transmission** - It's strongly recommended to use a high power fixed attenuator pad or an Isolator between the output port of the Amplifier and input port to the antenna. Any reflected signal power due to impedance mismatch will likely damage the Amplifier and void the warranty.
- 14.) The attenuator or isolator used at the output port of the Amplifier must be rated to handle the output power level and operational frequency band of the amplifier.

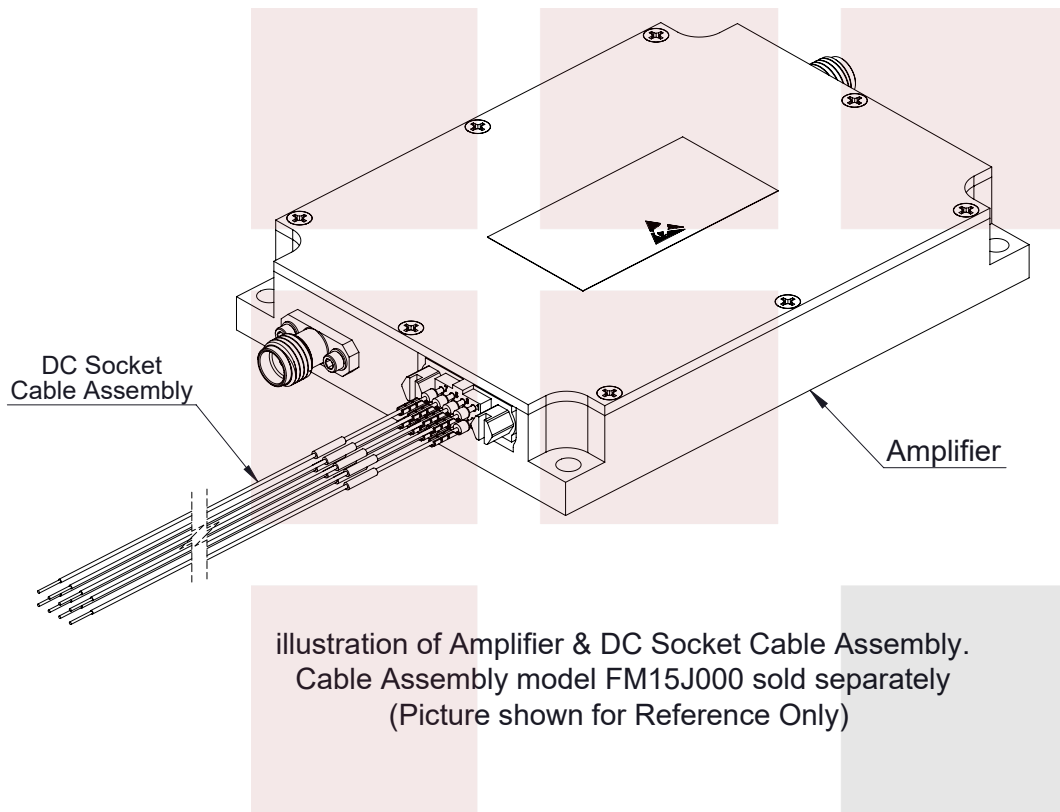

Typical Performance Data

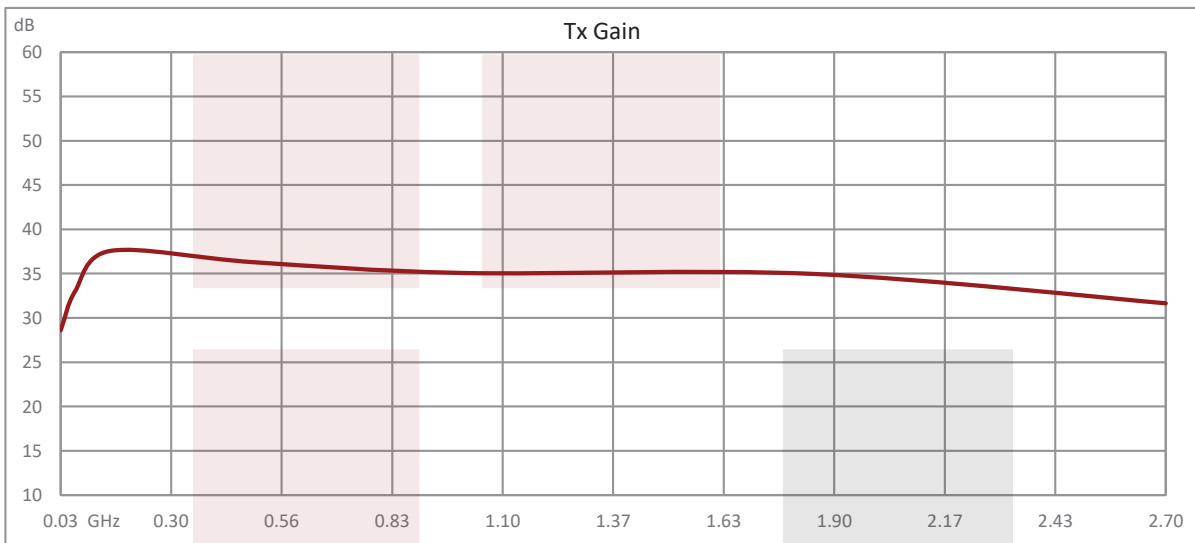
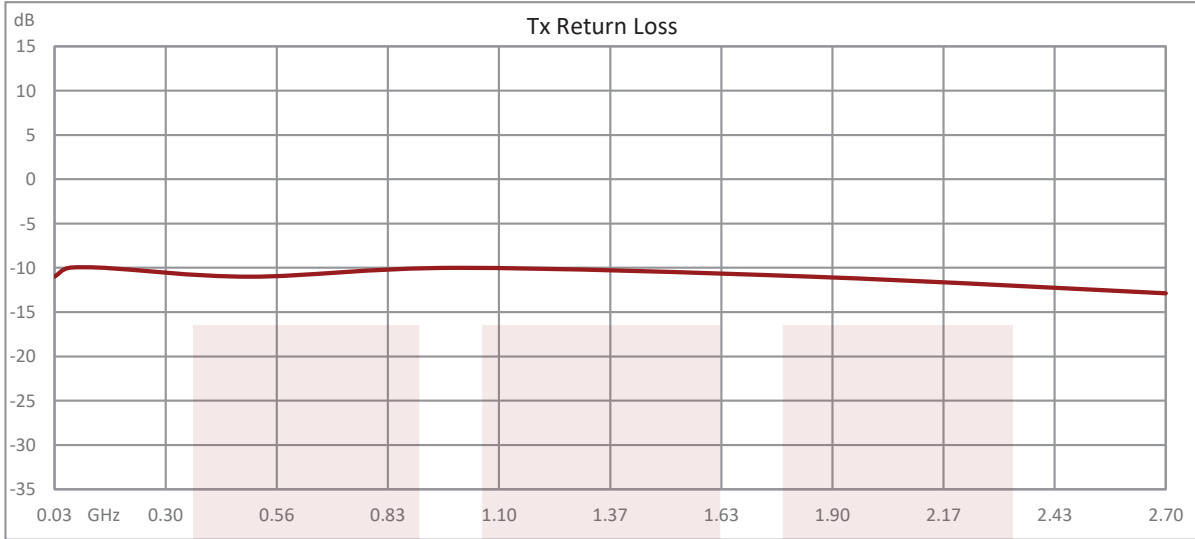

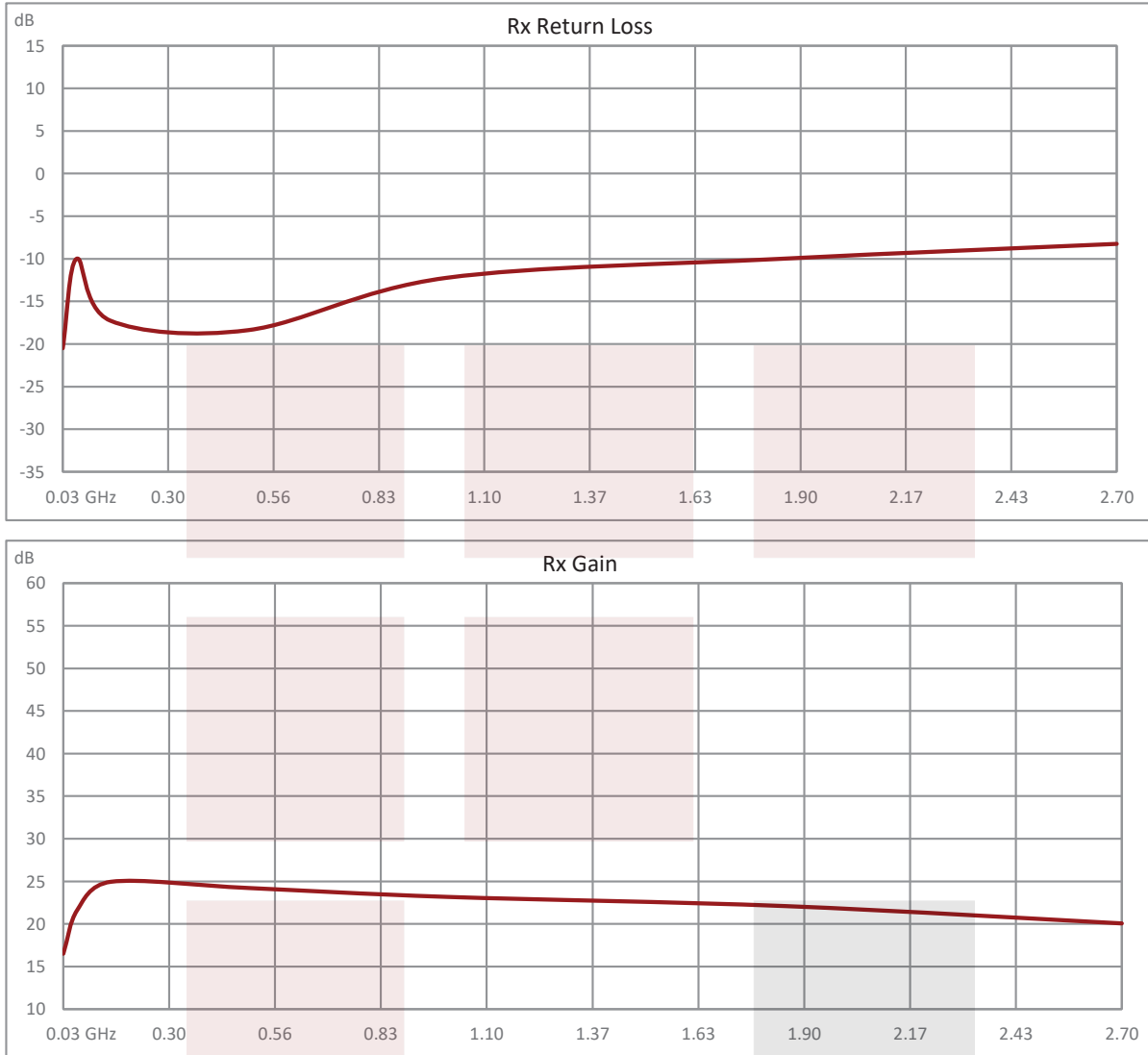

30 MHz to 2.7 GHz, SMA, GaN Bi-Directional Amplifier, High Power, 8W Psat, 36dB Tx Gain, 1 microsec speed, Manual T/R Control from Fairview Microwave is in-stock and available to ship same-day. All of our RF/microwave products are available off-the-shelf from our ISO 9001:2008 certified facilities in Lewisville, Texas. Fairview Microwave is RF on-demand.

For additional information on this product, please click the following link: [30 MHz to 2.7 GHz, SMA, GaN Bi-Directional Amplifier, High Power, 8W Psat, 36dB Tx Gain, 1 microsec speed, Manual T/R Control FM15B5003](#)

URL: <https://www.fairviewmicrowave.com/bi-directional-amplifier-power-0-0-watts-linear-fm15b5003-p.aspx>

The information contained in this document is accurate to the best of our knowledge and representative of the part described herein. It may be necessary to make modifications to the part and/or the documentation of the part, in order to implement improvements. Fairview Microwave reserves the right to make such changes as required. Unless otherwise stated, all specifications are nominal. Fairview Microwave does not make any representation or warranty regarding the suitability of the part described herein for any particular purpose, and Fairview Microwave does not assume any liability arising out of the use of any part or documentation.

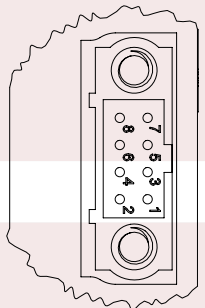
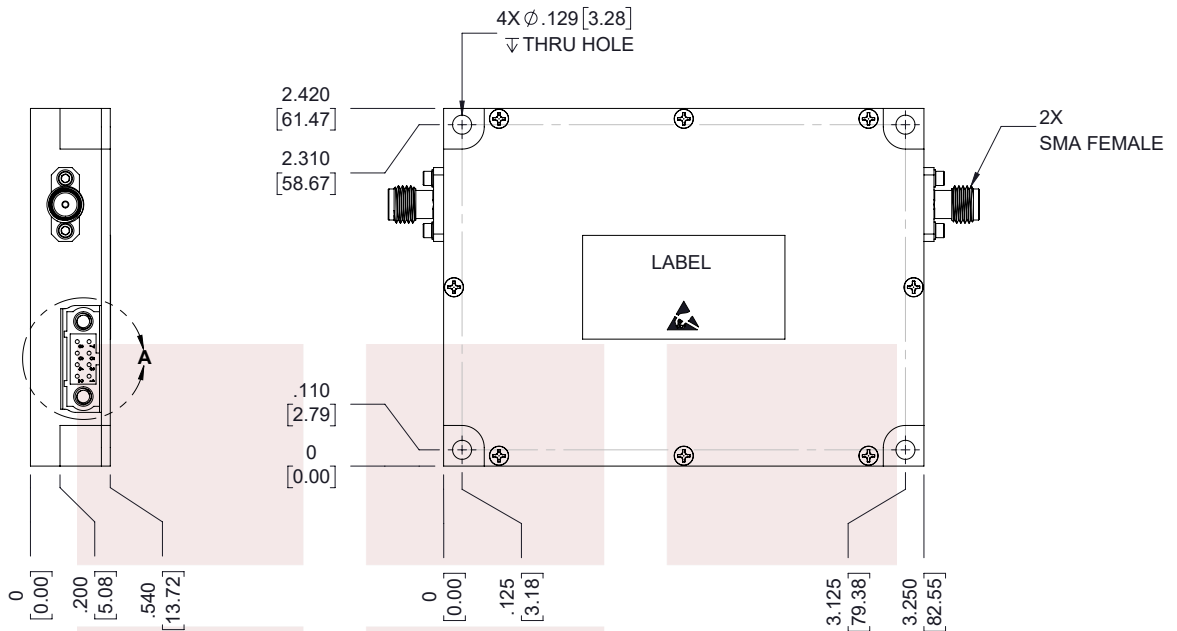

8 PIN RECTANGULAR MALE				
PIN	NAME	DESCRIPTION	TYPE	LEVEL
1	TEMP	Analog Temperature Sensor Output	Power	--
2,4,6	GND	Ground	Power	--
3	Tx/Rx	TTL Hi = Transmit Mode, TTL Lo or No Connection = Receive Mode	Input	5V TTL
5,7	+VDC	Min: +12V / Max: 30V	Power	--
8	SGND	Signal Ground	Input	--

LABEL



STANDARD TOLERANCES

- .X ±0.2
- .XX ±0.01
- .XXX ±0.005

*STANDARD TOLERANCES APPLY ONLY TO DIMENSIONS IN INCHES

NOTE: SPECIFICATION SUBJECT TO CHANGE WITHOUT NOTICE.
TYPICAL PERFORMANCE AT VDC AT 25°C IN A 50Ω SYSTEM.

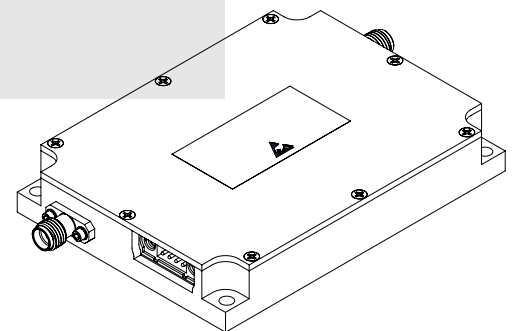

<p>Fairview Microwave an INFINIT® brand</p>		<p>NOTES: 1. UNLESS OTHERWISE SPECIFIED ALL DIMENSIONS ARE NOMINAL. 2. ALL SPECIFICATIONS ARE SUBJECT TO CHANGE WITHOUT NOTICE AT ANY TIME. 3. DIMENSIONS ARE IN INCHES [mm].</p>		
<p>TITLE 30 MHz to 2.7 GHz, SMA, GaN Bi-Directional Amplifier, High Power, 8W Psat, 36dB Tx Gain, 1 microsec speed, Manual T/R Control</p>		<p>DWG NO FM15B5003</p>		<p>CAGE CODE 3FKR5</p>
<p>CAD FILE</p>		<p>SHEET 1 OF 1</p>	<p>SCALE N/A</p>	<p>SIZE A</p>