

Hermetically Sealed TNC Female to TNC Female Bulkhead Adapter MIL-STD-202, Method 206 18GHz VSWR1.35, MIL-STD 348B with Stainless Steel Body

Hermetically sealed TNC female to TNC female bulkhead adapter part number FMAD1355 from Fairview Microwave is in-stock and ships same day. This Fairview TNC to TNC adapter has a female to female gender configuration and is built of durable stainless steel. FMAD1355 TNC female to TNC female adapter operates to 18 GHz. The Fairview Microwave RF adapter provides good VSWR of 1.35:1 maximum. Our RF TNC to TNC bulkhead adapter allows designers to create external connections on their product enclosures, and can be used in a variety of other rack mount and panel mount applications. The Fairview Microwave hermetic TNC to TNC adapter prevents the leakage of gases, making it suitable for high pressure or vacuum applications or whenever an airtight seal is required.

RF adapters can be used to enable connections between two connector types that would otherwise not mate. Certain RF adapter configurations can also be used to protect connectors on expensive equipment where the number of connect and disconnect cycles is high. An RF, microwave, or millimeter wave adapter is connected to the equipment and the commonly changed connection is made with the adapter which can be easily replaced when it wears out after high usage; such adapters are referred to as connector savers. Fairview Microwave also offers bulkhead, panel mount, hermetically sealed, reverse polarity, and isolated ground adapter varieties to serve all of your RF, microwave and millimeter wave needs.

Electrical Specifications

Description	Min	Typ	Max	Units
Frequency Range	DC		18	GHz
VSWR			1.35:1	
Insertion Loss			0.21	dB
Operating Voltage (AC)			500	Vrms
DWV (AC)			1,000	Vrms
Insulation Resistance	5,000			MOhms

Mechanical Specifications

Size	
Length	1.39 in [35.31 mm]
Width	0.63 in [16.00 mm]
Height	0.63 in [16.00 mm]
Weight	0.04 lbs [18.14 g]

Description	Connector 1	Connector 2
Type	TNC Female	TNC Female
Polarity	Standard	Standard
Connector Option	Hermetically Sealed	Hermetically Sealed
Mating Cycles, Min	500	500
Mating Torque	4.1 to 6.1 in-lbs [0.46 to 0.69 Nm]	4.1 to 6.1 in-lbs [0.46 to 0.69 Nm]
Contact Captivation Axial Force, Min	6.1 lbs [2.77 kg]	6.1 lbs [2.77 kg]
Coupling Proof Torque	15 in-lbs [1.7 Nm]	15 in-lbs [1.7 Nm]



Configuration:

- TNC Female Connector 1
- TNC Female Connector 2
- 50 Ohm
- Straight Body Geometry
- Bulkhead Mount Method

Features:

- VSWR of 1.35:1 max up to 18 GHz
- Hermetically Sealed
- Gold Plated Beryllium Copper Contact

Applications:

- General Purpose Test
- Vacuum Test Environment
- Rack Mounted Equipment

Fairview Microwave
301 Leora Ln., Suite 100
Lewisville, TX 75056
Tel: 1-800-715-4396 / (972) 649-6678
Fax: (972) 649-6689
www.fairviewmicrowave.com
sales@fairviewmicrowave.com

Material Specifications

Description	Connector 1	Connector 2
Type	TNC Female	TNC Female
Contact Material	Beryllium Copper	Beryllium Copper
Contact Plating	Gold	Gold
Insulation Material	PTFE	PTFE
Outer Contact Material	Stainless Steel	Stainless Steel
Outer Contact Plating	Passivated	Passivated
Body Material	Stainless Steel	Stainless Steel
Body Plating	Passivated	Passivated

Environmental Specifications
Temperature

Operating Range

Humidity

Thermal Shock

Salt Spray

Hermetic Seal

-10 to +165 deg C

MIL-STD-202, Method 206

MIL-STD-202, Method 107, Condition B

MIL-STD-202, Method 101, Condition B

 1*10⁻⁸ cc/sec of HELIUM at 1 ATM

Compliance Certifications (see [product page](#) for current document)

Plotted and Other Data

Notes:

Hermetically Sealed TNC Female to TNC Female Bulkhead Adapter MIL-STD-202, Method 206 18GHz VSWR1.35, MIL-STD 348B with Stainless Steel Body from Fairview Microwave is in-stock and available to ship same-day. All of our RF/microwave products are available off-the-shelf from our ISO 9001:2008 certified facilities in Lewisville, Texas. Fairview Microwave is RF on-demand.

For additional information on this product, please click the following link: [Hermetically Sealed TNC Female to TNC Female Bulkhead Adapter MIL-STD-202, Method 206 18GHz VSWR1.35, MIL-STD 348B with Stainless Steel Body FMAD1355](#)

URL: <https://www.fairviewmicrowave.com/hermetically-sealed-tnc-female-to-tnc-female-bulkhead-adapter-mil-std-202-method-206-18ghz-vswr1.35-mil-std-348b-with-stainless-steel-body-fmad1355-p.aspx>

The information contained in this document is accurate to the best of our knowledge and representative of the part described herein. It may be necessary to make modifications to the part and/or the documentation of the part, in order to implement improvements. Fairview Microwave reserves the right to make such changes as required. Unless otherwise stated, all specifications are nominal. Fairview Microwave does not make any representation or warranty regarding the suitability of the part described herein for any particular purpose, and Fairview Microwave does not assume any liability arising out of the use of any part or documentation.

REVISIONS			
REV.	DESCRIPTION	DATE	APPROVED
A	INITIAL RELEASE	12/12/2022	AGANWANI

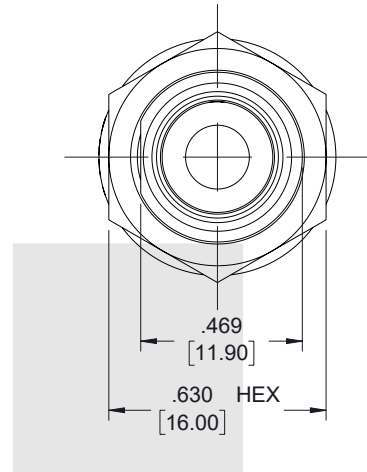
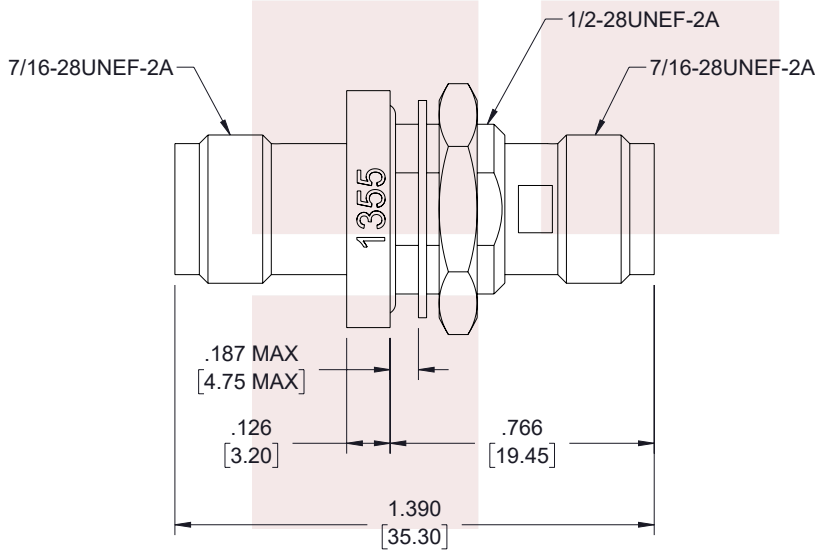
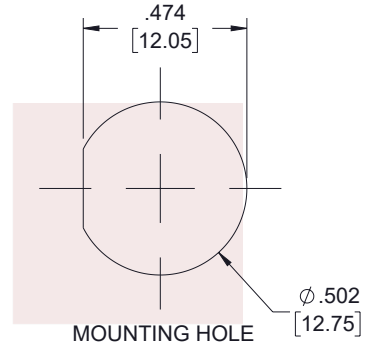
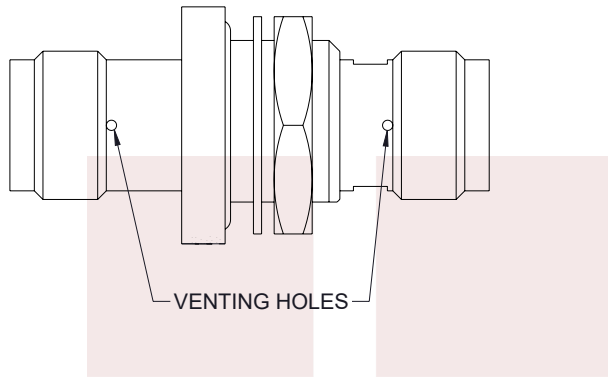

THESE COMMODITIES, TECHNOLOGY OR SOFTWARE WERE EXPORTED FROM THE UNITED STATES IN ACCORDANCE WITH THE EXPORT ADMINISTRATION REGULATIONS. DIVERSION CONTRARY TO U.S. LAW PROHIBITED.

TITLE

UNLESS OTHERWISE SPECIFIED LEADING DIMENSIONS ARE INCHES
DIMENSIONS IN [] ARE MILLIMETERS

TOLERANCES: CABLE LENGTH (L) TOLERANCES:

.X = ±.2 [5.08] FRACTIONS L ≤ 12 [305] = +1 [25] / -0
.XX = ±.02 [.51] ± 1/32 12 [305] < L ≤ 60 [1524] = +2 [51] / -0
.XXX = ±.005 [.13] ANGLES ± 1° 60 [1524] < L ≤ 120 [3048] = +4 [102] / -0
120 [3048] < L ≤ 300 [7620] = +6 [152] / -0
300 [7620] < L = +5%L / -0

THIRD-ANGLE PROJECTION



THE INFORMATION AND DESIGN IN THIS DOCUMENT IS THE PROPERTY OF FAIRVIEW MICROWAVE CORPORATION. ALL RIGHTS RESERVED.

SHEET 1 OF 1

ALL DIMENSIONS SHOWN ARE FOR REFERENCE ONLY.

SCALE N/A

SIZE A	CAGE CODE 3FKR5	DRAWN BY HBAKKE	ITEM NO. FMAD1355	REV A
-----------	--------------------	--------------------	----------------------	----------

T-Rev.D