

48 dB Gain High Power GaN Amplifier at 50 Watt Psat Operating from 500 MHz to 3 GHz with 52 dBm IP3, SMA Input, SMA Output

FMAM5032 is a high gain Class A/AB GaN Linear Power Amplifier operating in the 500 to 3000 MHz frequency range. The amplifier offers a Wide Dynamic Range with 50 Watts typical saturated power, 48 dB minimum small signal gain, and ± 2.0 dB gain flatness maximum. The amplifier requires typically a +36V DC power supply, is unconditionally stable, and operates over the temperature range of -20°C and $+75^{\circ}\text{C}$. Pinouts include TTL Blanking, Remote ON/OFF, DC Current Monitoring, Reset, And Temperature Sensor Monitoring. RF Input/Output Connectors are SMA Female.



Electrical Specifications

(TA = $+25^{\circ}\text{C}$)

Description	Min	Typ	Max	Unit
Frequency Range	0.5		3	GHz
Small Signal Gain	48			dB
Gain Flatness			± 2	dB
Input Power (CW)			+0	dBm
Psat	+46.5	+47		dBm
P1dB		+44		dBm
P1dB at OTR*	+43			dBm
Output 3rd Order Intercept Point		+52		dBm
Harmonics @20 Watts		-15		dBc
Spurious @20 Watts		-70	-60	dBc
Impedance (Input)		50		Ohms
Impedance (Output)		50		Ohms
Input VSWR			2:1	
TTL Control	"1": Off, "0": On (Blanking), Enable: 0V, Disable: 5V			
Operating DC Voltage	+28	+36	+42	Volts
Operating DC Current		8.333		A
DC Consumption			300	Watts
Operating Temperature Range	-20		+75	$^{\circ}\text{C}$
Temperature Indication: Analog Voltage Reporting with LM 35 or Equivalent				

Current Indication: Analog Voltage Reporting

*OTR= Base Plate Operating Temperature Range

Mechanical Specifications

Size	
Length	6 in [152.4 mm]
Width	5 in [127 mm]
Height	1.1 in [27.94 mm]
Weight	2 lbs [907.18 g]
Input Connector	SMA Female
Output Connector	SMA Female
Cooling	ADEQUATE HEATSINK REQUIRED

Environmental Specifications

Features:

- 500 MHz to 3000 MHz Frequency Range
- Psat 50 Watts typ
- Small Signal Gain: 48 dB min
- Gain Flatness ± 2.0 dB max
- Class A/AB
- TTL Blanking
- Remote ON/OFF
- 50 Ohms Input and Output Matched
- Unconditionally Stable
- Regulated Supply
- RF Input Signal Format CW/AM/FM/PM/Pulse
- SMA Female RF Connectors
- DC Current Monitoring
- Rest Control
- Temperature Sensor Monitoring

Applications:

- Military Radio
- Communication Systems
- High Gain Driver Power Amplifier
- Medical Industry
- High Gain Output Power Amplifier

Fairview Microwave
301 Leora Ln., Suite 100
Lewisville, TX 75056
Tel: 1-800-715-4396 / (972) 649-6678
Fax: (972) 649-6689
www.fairviewmicrowave.com
sales@fairviewmicrowave.com

Temperature

Operating Range	-20 to +75 deg C
Humidity	95
Shock	MIL-STD-810F Method 516.5
Vibration	MIL-STD-810F Method 516.5
Altitude	10000

Compliance Certifications (see [product page](#) for current document)

Plotted and Other Data

Notes:

- Values at 25 °C, sea level
- ESD Sensitive Material, Transport material in Approved ESD bags. Handle only in approved ESD Workstation.
- Heat Sink Required for Proper Operation, Unit is cooled by conduction to heat sink.

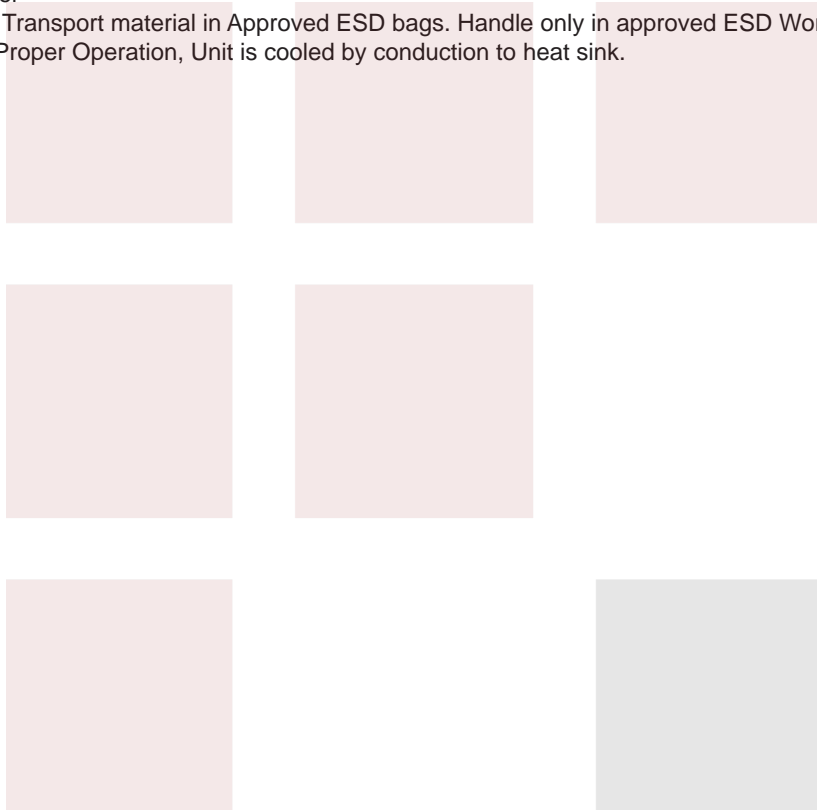

Amplifier Power-up Precautions

- 1.) Confirm that proper ESD precautions and controls are always in place before handling any Amplifier module.
- 2.) Confirm adequate thermal management is in place to effectively dissipate heat away from the Amplifier package. The Amplifier operational baseplate temperature must be within the operational temperature range stated in the Amplifier datasheet. Depending on the design and thermal requirements, using a heatsink with cooling fan is always recommended for safe reliable operation. A heat sink without a cooling fan may also be used. Damage caused from overheating will void the warranty.
- 3.) Confirm adequate system grounding is established. The DC power supply and Amplifier must have a common ground in order to operate properly.
- 4.) Power Amplifiers may require additional DC Current when initially powered-up. Depending on the design, the input current draw could range from an additional 10% to 100% above the maximum rated DC current of the Amplifier. This varies based on product part number.
- 5.) Confirm the DC power supply, if limited, is set to allow for additional start-up current that's rated for the Power Amplifier.
- 6.) Confirm the system is designed and calibrated for 50 ohms. Any impedance mismatch may cause performance issues.
- 7.) Perform a CALIBRATION (if required) with the loads before connecting the Amplifier to the Network Analyzer to ensure proper performance.
- 8.) Use a fixed attenuator between the signal source and input port of the Amplifier to optimize the input VSWR match.
- 9.) Confirm the input power level at the input port of the amplifier does not exceed the maximum rated limit for input power (as stated in the Amplifier datasheet).
 P_{in} for Small Signal Gain = P1dB-SSG-10 dB
 P_{in} for P1dB = P1dB-SSG+1 dB
- 10.) Confirm the Network Analyzer is always connected to the Amplifier first before DC power is applied to the Amplifier.
- 11.) As long as the input and output ports of the amplifier are connected to a 50Ohm load and RF signal power is applied, the Amplifier can be powered up with DC voltage.
- 12.) Confirm the Amplifier output load is matched for a 50 Ohm impedance and will not exceed the maximum rated VSWR or Return Loss limit for the Amplifier. Exceeding the maximum rated VSWR or Return Loss limit will result in reflected signal power that could damage the Amplifier and void the warranty.
- 13.) **Power Amplifier connected to an Antenna for signal transmission** - It's strongly recommended to use a high power fixed attenuator pad or an Isolator between the output port of the Amplifier and input port to the antenna. Any reflected signal power due to impedance mismatch will likely damage the Amplifier and void the warranty.
- 14.) The attenuator or isolator used at the output port of the Amplifier must be rated to handle the output power level and operational frequency band of the amplifier.

Power Up Sequence

For Turn On:

1. Initially, NO RF INPUT
2. On/Off and Blanking Pins set to Ground (Logic 0). This will keep the module in the Disable and blanked condition (no amplification) during Voltage (+32VDC) turn on.
3. Turn the Voltage (+32VDC) on.
4. Turn on Voltage (TTL +5VDC or +3.3VDC) to On/Off and Blanking Pins. This will enable and un-blank the module (amplification).
5. Turn on the Signal Source (-25dBm) on the RF input.

For Turn Off:

1. Turn off the Signal Source on the RF input.
2. On/Off and Blanking Pins set to Ground (Logic 0). This will keep the module in the Disable and blanked condition (no amplification) during Voltage (+32VDC) turn off.
3. Turn off the Voltage (+32VDC).

Typical Performance Data

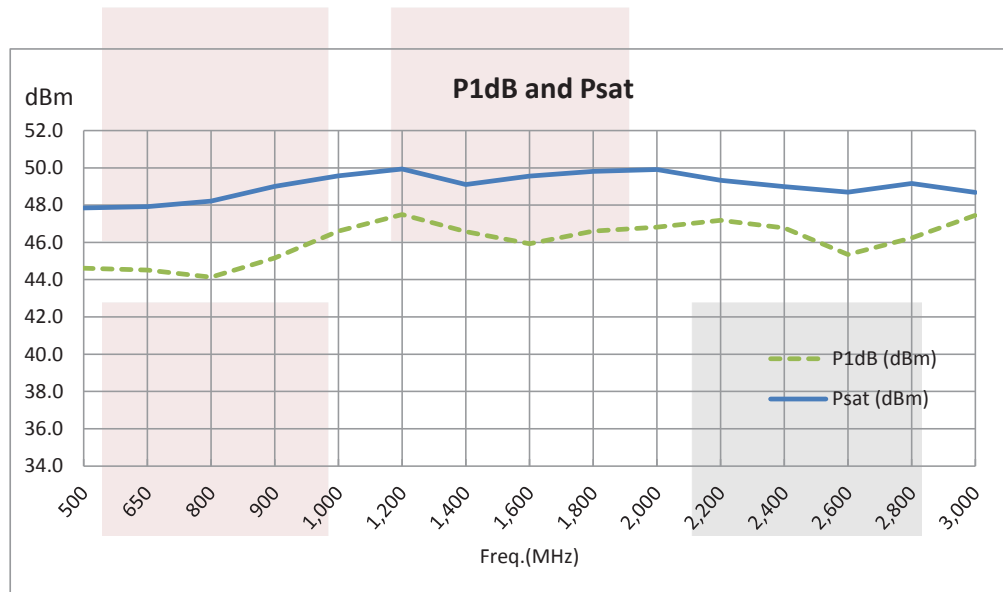
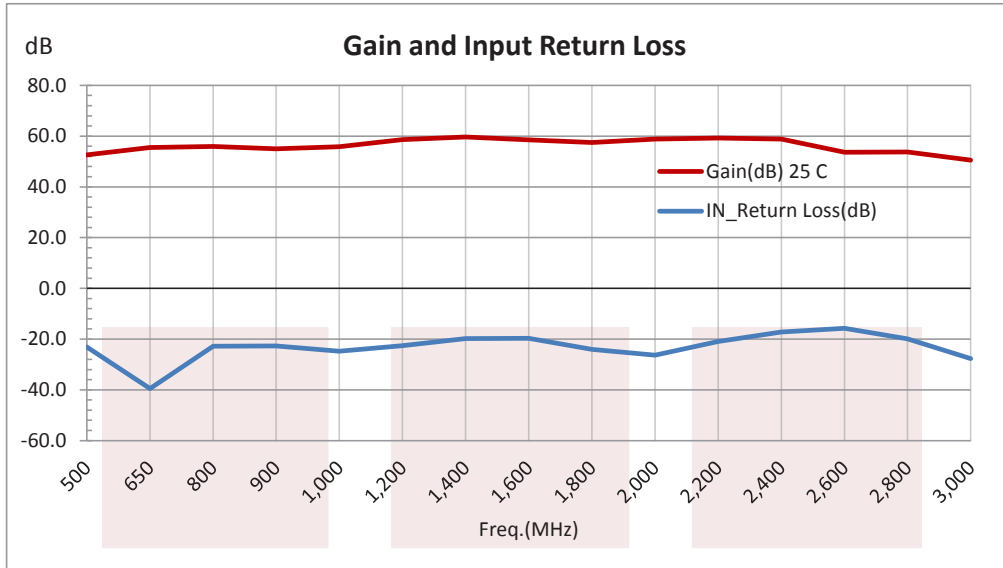

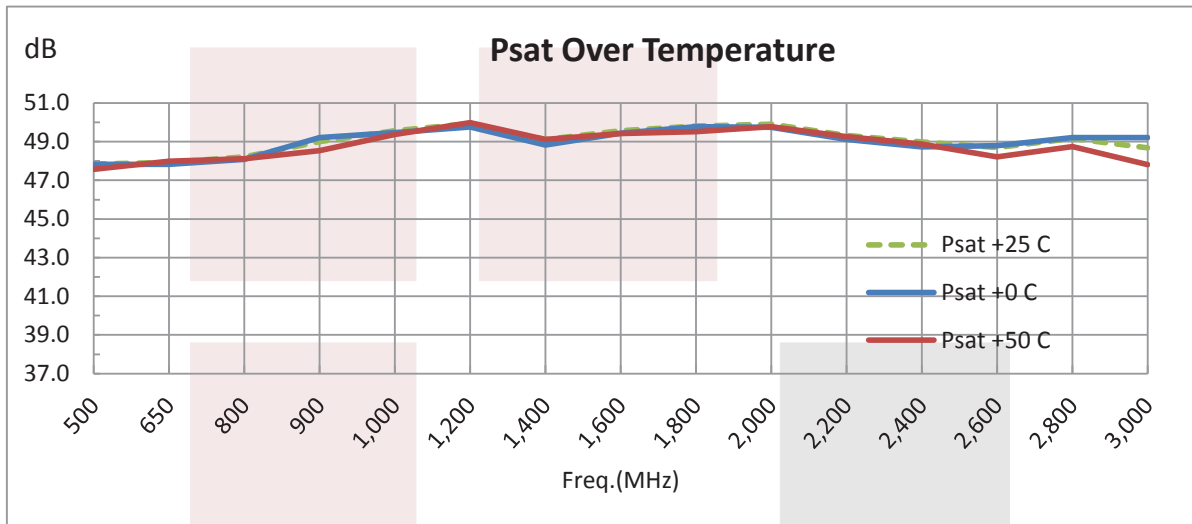
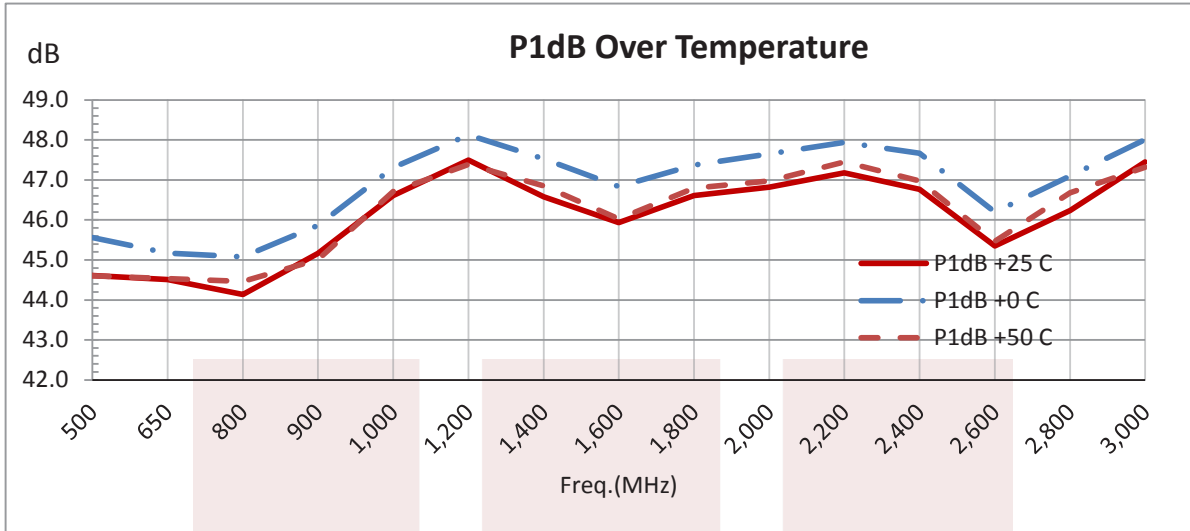

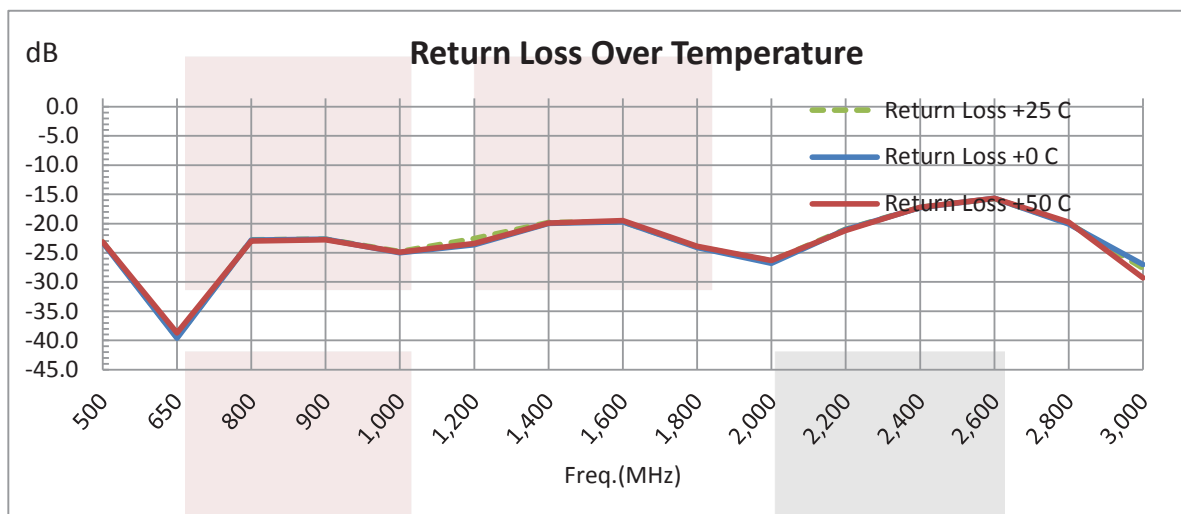
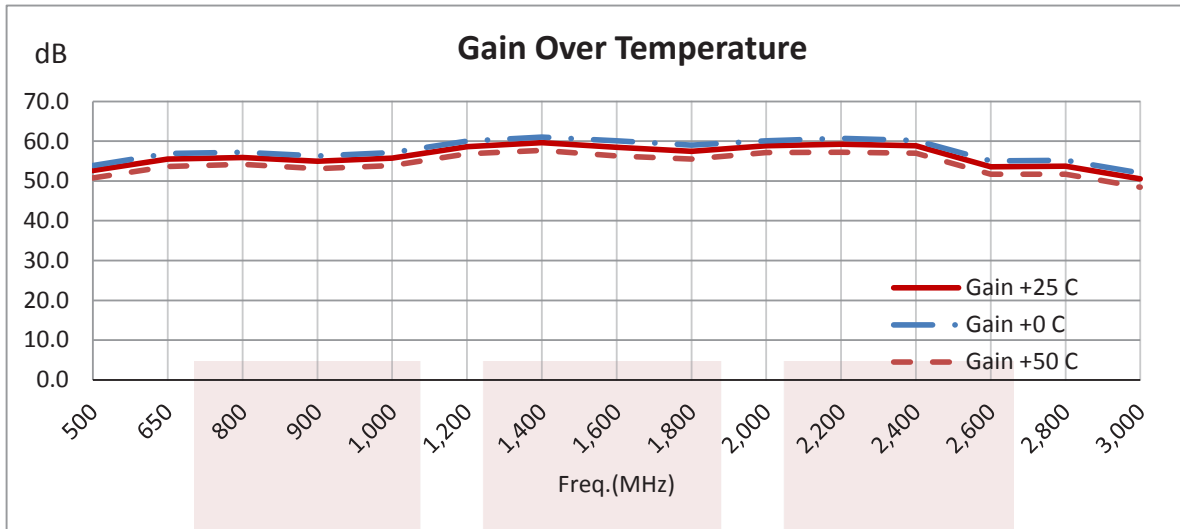

48 dB Gain High Power GaN Amplifier at 50 Watt Psat Operating from 500 MHz to 3 GHz with 52 dBm IP3, SMA Input, SMA Output from Fairview Microwave is in-stock and available to ship same-day. All of our RF/microwave products are available off-the-shelf from our ISO 9001:2008 certified facilities in Lewisville, Texas. Fairview Microwave is RF on-demand.

For additional information on this product, please click the following link: [48 dB Gain High Power GaN Amplifier at 50 Watt Psat Operating from 500 MHz to 3 GHz with 52 dBm IP3, SMA Input, SMA Output FMAM5032](https://www.fairviewmicrowave.com/48db-high-power-high-gain-amplifier-50watt-fmam5032-p.aspx)

URL: <https://www.fairviewmicrowave.com/48db-high-power-high-gain-amplifier-50watt-fmam5032-p.aspx>

The information contained in this document is accurate to the best of our knowledge and representative of the part described herein. It may be necessary to make modifications to the part and/or the documentation of the part, in order to implement improvements. Fairview Microwave reserves the right to make such changes as required. Unless otherwise stated, all specifications are nominal. Fairview Microwave does not make any representation or warranty regarding the suitability of the part described herein for any particular purpose, and Fairview Microwave does not assume any liability arising out of the use of any part or documentation.

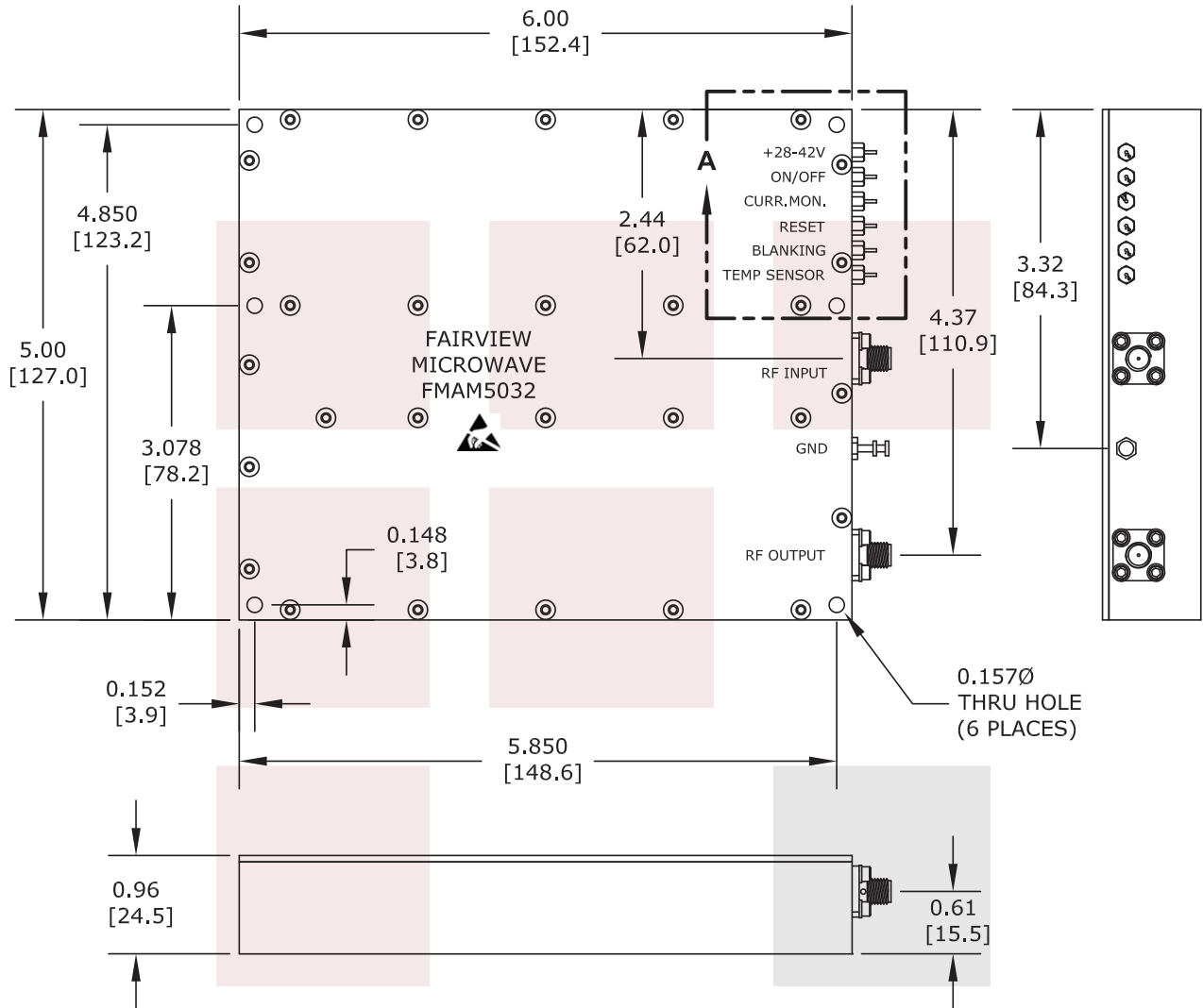

NOTE:
HEAT SINK REQUIRED FOR PROPER OPERATION,
UNIT IS COOLED BY CONDUCTING TO HEAT SINK.

FAIRVIEW MICROWAVE INC. ALLEN, TX 75013 WWW.FAIRVIEWMICROWAVE.COM		NOTES: 1. UNLESS OTHERWISE SPECIFIED ALL DIMENSIONS ARE NOMINAL. 2. ALL SPECIFICATIONS ARE SUBJECT TO CHANGE WITHOUT NOTICE AT ANY TIME. 3. DIMENSIONS ARE IN INCHES [mm].			
TITLE 48 dB Gain High Power GaN Amplifier at 50 Watt Psat Operating from 500 MHz to 3 GHz with 52 dBm IP3, SMA Input, SMA Output		DWG NO FMAM5032		CAGE CODE 3FKR5	
CAD FILE	042815	SHEET	SCALE	N/A	SIZE A 2233

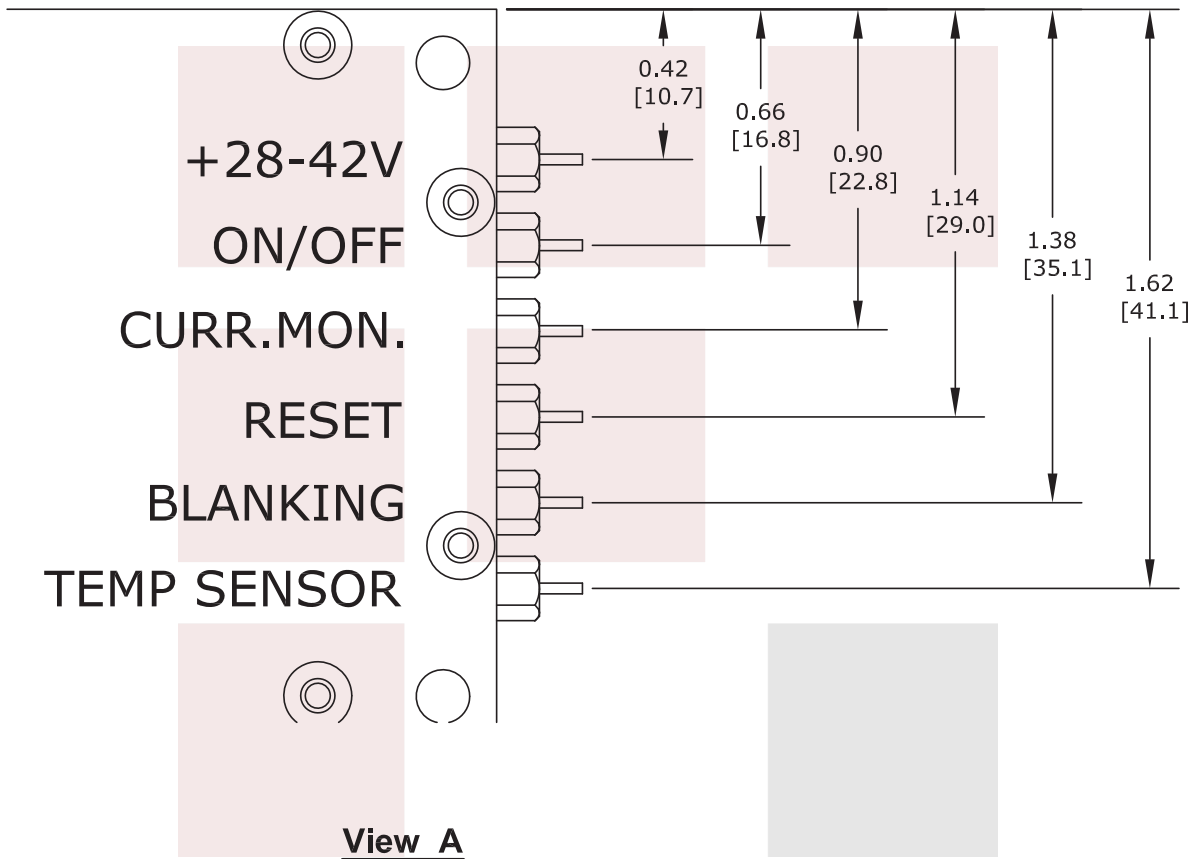

NOTE:
HEAT SINK REQUIRED FOR PROPER OPERATION,
UNIT IS COOLED BY CONDUCTING TO HEAT SINK.

FAIRVIEW MICROWAVE INC. ALLEN, TX 75013 WWW.FAIRVIEWMICROWAVE.COM		NOTES: 1. UNLESS OTHERWISE SPECIFIED ALL DIMENSIONS ARE NOMINAL. 2. ALL SPECIFICATIONS ARE SUBJECT TO CHANGE WITHOUT NOTICE AT ANY TIME. 3. DIMENSIONS ARE IN INCHES [mm].			
TITLE 48 dB Gain High Power GaN Amplifier at 50 Watt Psat Operating from 500 MHz to 3 GHz with 52 dBm IP3, SMA Input, SMA Output		DWG NO FMAM5032		CAGE CODE 3FKR5	
CAD FILE	042815	SHEET	SCALE	N/A	SIZE A 2233