

144/430 MHz, Gooseneck Antenna, SMA Female Connector

FMANOM1155



Features

- 144/430 MHz Operating Frequency
- Flexible Gooseneck
- SMA Female Connector
- 1.5:1 VSWR
- 10 Watt Max Input Power
- Typical 3 dBi Gain

Applications

- Unmanned Vehicles
- Manpack Radio Systems
- Secure Communications
- Surveillance Systems
- Mobile Systems

Description

The FMANOM1155 from Fairview Microwave is an omnidirectional gooseneck antenna that features a flexible gooseneck mounting base. This flexible antenna can be bent and repositioned at any angle, allowing users to optimize signal reception and transmission in any environment. Our dual-band gooseneck antenna with vertical polarization can operate at frequencies ranging from 144 to 430 MHz.

Fairview Microwave's FMANOM1155 gooseneck antenna has an impedance of 50 Ohms and a maximum input power of 10 Watts. This omnidirectional antenna is designed to withstand temperatures ranging from -40 to 80 degrees C. Our vertical polarized antenna has an overall length of 12.4 inches, a width of 1.5 inches, and a weight of 0.33 lbs. This gooseneck antenna is lightweight and compact, making it easy to transport and deploy in the field.

This vertically polarized antenna has a maximum input VSWR of 1.5:1. Our dual-band gooseneck antenna with an SMA female connector has a band 1 gain of 3.5 dBi and a band 2 gain of 5.5 dBi. This FMANOM1155 antenna comes with a black TPE radome that offers a protective covering without compromising the antenna system's performance.

Configuration

Design	Gooseneck
Band Type	Dual
Radiation Pattern	Omni Directional
Polarization	Vertical
Connector Type	SMA Female

Electrical Specifications

Description	Minimum	Typical	Maximum	Units
Frequency Range	144		430	MHz
Input VSWR			1.5:1	
Impedance		50		Ohms
Input Power			10	Watts

Specifications by Band

Description	Band 1	Band 2	Band 3	Band 4	Band 5	Units
Center Frequency	144	430				MHz
Gain	3.5	5.5				dBi

144/430 MHz, Gooseneck Antenna, SMA Female Connector

FMANOM1155



Mechanical Specifications

Radome Material	TPE
Size	
Length	13 in [330.2 mm]
Width	1.5 in [38.1 mm]
Height	1.5 in [38.1 mm]
Weight	0.5 lbs [226.8 g]

Environmental Specifications

Temperature	
Operating Range	-40 to +80 deg C

Compliance Certifications (see [product page](#) for current document)

Plotted and Other Data

Notes:

144/430 MHz, Gooseneck Antenna, SMA Female Connector

FMANOM1155



Typical Radiation Pattern

Appendix

Electrical Downtilt: Angle in the antenna's elevation pattern in which the maximum gain occurs.

Gain: Antenna's average gain.

Front to Back Ratio @ 180°±30°: Average difference between the antenna's maximum gain and the maximum gain in the antenna's back lobe over ±30° angles.

Cross-polarization Ratio (dB): Typical difference between the co-polarization and cross-polarization gain across the sector's 3 dB Beam Width.

Dedicated to serving the needs of the Wireless Internet Service Provider (WISP) market, KP Performance Antennas offers purpose built products that reliably perform in the field. KP Performance Antennas product line consists of Yagi, Grid, Omni, Dish and other style antennas that operate in the 900 MHz, 2.4 GHz, 3 GHz, and 5 GHz frequencies.

144/430 MHz, Gooseneck Antenna, SMA Female Connector from Fairview Microwave is in-stock and available to ship same-day. All of our RF/microwave products are available off-the-shelf from our ISO 9001:2008 certified facilities in Lewisville, Texas. Fairview Microwave is RF on-demand.

For additional information on this product, please click the following link: [144/430 MHz, Gooseneck Antenna, SMA Female Connector FMANOM1155](https://www.fairviewmicrowave.com/dualband-gooseneck-antenna-144-430-mhz-sma-connector-fmanom1155-p.aspx)

URL: <https://www.fairviewmicrowave.com/dualband-gooseneck-antenna-144-430-mhz-sma-connector-fmanom1155-p.aspx>

The information contained within this document is accurate to the best of our knowledge and representative of the part described herein. It may be necessary to make modifications to the part and/or the documentation of the part in order to implement improvements. Fairview Microwave reserves the right to make such changes as required. Unless otherwise stated, all specifications are nominal. Fairview Microwave does not make any representation or warranty regarding the suitability of the part described herein for any particular purpose, and Fairview Microwave does not assume liability arising out of the use of any part or document.

FMANOM1155 CAD Drawing

144/430 MHz, Gooseneck Antenna, SMA Female Connector

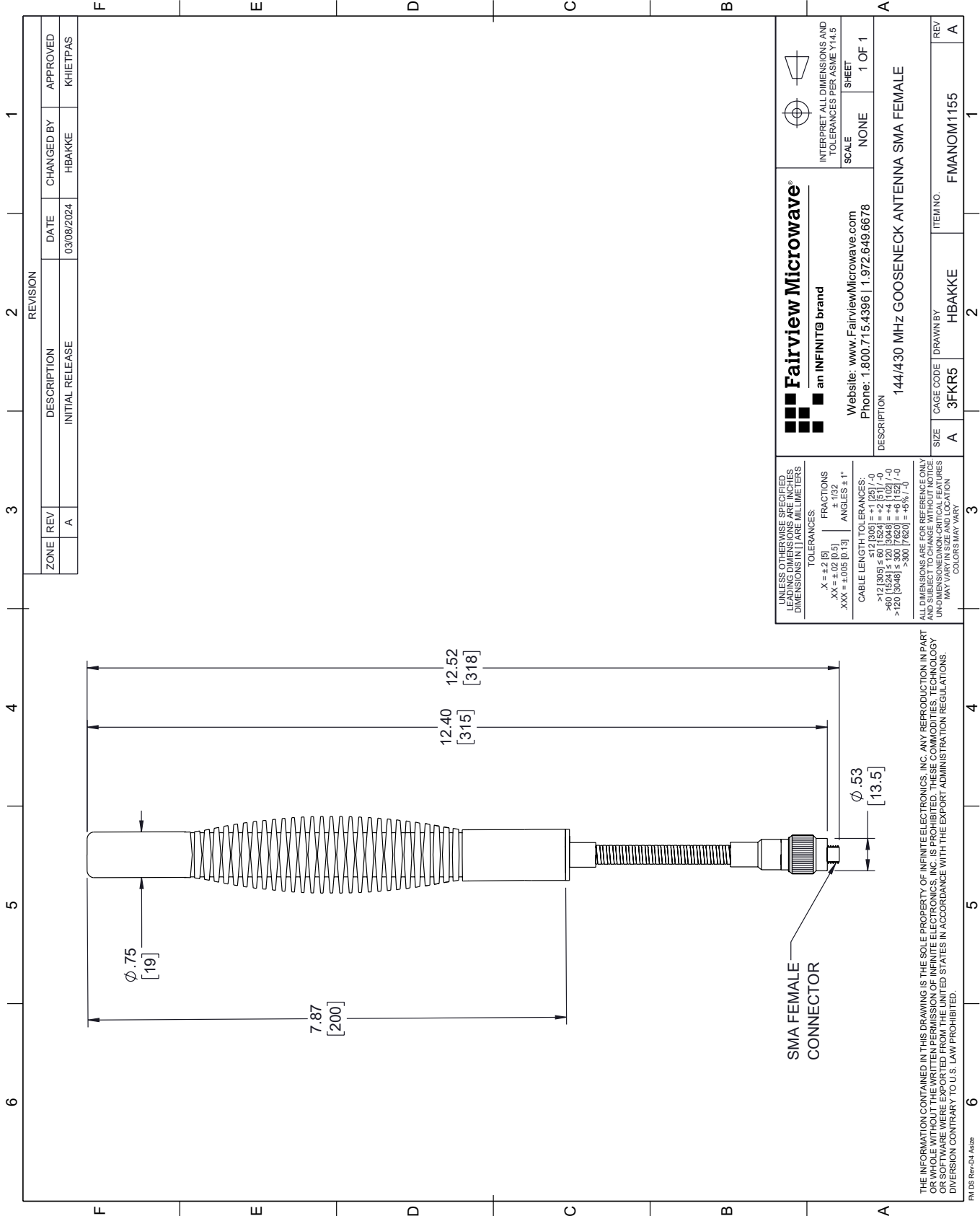

REVISION		DATE	CHANGED BY	APPROVED	
ZONE	REV	DESCRIPTION	DATE	CHANGED BY	APPROVED
	A	INITIAL RELEASE	03/08/2024	HBAKKE	KHIEPPAS

Fairview Microwave®
an INFINIT® brand

Website: www.FairviewMicrowave.com
Phone: 1.800.715.4396 | 1.972.649.6678

SCALE: NONE
SHEET: 1 OF 1

INTERPRET ALL DIMENSIONS AND TOLERANCES PER ASME Y14.5

DESCRIPTION: 144/430 MHz GOOSENECK ANTENNA SMA FEMALE

SIZE	CAGE CODE	DRAWN BY	ITEM NO.	REV
A	3FKR5	HBAKKE	FMANOM1155	A

UNLESS OTHERWISE SPECIFIED, LEADING DIMENSIONS ARE IN INCHES AND DIMENSIONS IN [] ARE MILLIMETERS

TOLERANCES:
 .X = ±.2 [5]
 .XX = ±.02 [0.5]
 .XXX = ±.005 [0.13]

FRACTIONS: ± 1/32
 ANGLES: ± 1°

CABLE LENGTH TOLERANCES:
 <12 [305] ±.60 [15.24] = ±.2 [5] / -0
 >12 [305] ≤ 60 [1524] = ±.4 [10.2] / -0
 >60 [1524] ≤ 120 [3048] = ±.4 [10.2] / -0
 >120 [3048] ≤ 300 [7620] = ±.6 [15.24] / -0
 >300 [7620] = ±.8 [20.32] / -0

ALL DIMENSIONS ARE FOR REFERENCE ONLY. UNLESS OTHERWISE SPECIFIED, DIMENSIONS ARE IN INCHES AND DIMENSIONS IN [] ARE MILLIMETERS. UNLESS OTHERWISE SPECIFIED, DIMENSIONS ARE IN INCHES AND DIMENSIONS IN [] ARE MILLIMETERS. COLORS MAY VARY.

THE INFORMATION CONTAINED IN THIS DRAWING IS THE SOLE PROPERTY OF INFINITE ELECTRONICS, INC. ANY REPRODUCTION IN PART OR WHOLE WITHOUT THE WRITTEN PERMISSION OF INFINITE ELECTRONICS, INC. IS PROHIBITED. THESE COMMODITIES, TECHNOLOGY OR SOFTWARE ARE EXPORTED FROM THE UNITED STATES IN ACCORDANCE WITH THE EXPORT ADMINISTRATION REGULATIONS. DIVISION CONTRARY TO U.S. LAW PROHIBITED.

FM DS Rev-D4 Alt2b