

RA BNC Male Connector Crimp/Crimp Attachment For RG58 Cable

Electrical Specifications

Description	Min	Typ	Max	Units
Frequency Range	DC		3	GHz
VSWR			1.3:1	
Operating Voltage (AC)			500	Vrms

Mechanical Specifications

Size	Value
Length	1.345 in [34.16 mm]
Width/Dia.	0.571 in [14.50 mm]
Height	1.15 in [29.21 mm]
Weight	0.055 lbs [24.95 g]

Material Specifications

Description	Material	Plating
Contact	Brass	Gold 30µ in. minimum
Insulation	Teflon	
Body	Brass	Nickel 100µ in. minimum
Coupling Nut	Brass	Nickel 100µ in. minimum

Environmental Specifications

Temperature	Value
Operating Range	-65 to 165 deg C

Compliance Certifications (visit www.FairviewMicrowave.com for current document)

RoHS Compliant	Yes
REACH Compliant	12/17/2015



Configuration:

- BNC Male Connector
- MIL-STD-348A
- 50 Ohms
- Right Angle Body Geometry
- RG58 Interface Type
- Crimp/Crimp Attachment

Fairview Microwave
 1130 Junction Dr. #100
 Allen, TX 75013
 Tel: 1-800-715-4396 / (972) 649-6678
 Fax: (972) 649-6689
www.fairviewmicrowave.com
sales@fairviewmicrowave.com

Plotted and Other Data

Notes:

RA BNC Male Connector Crimp/Crimp Attachment For RG58 Cable from Fairview Microwave is in-stock and available to ship same-day. All of our RF/microwave products are available off-the-shelf from our ISO 9001:2008 certified facilities in Allen, Texas. Fairview Microwave is RF on-demand.

For additional information on this product, please click the following link: [RA BNC Male Connector Crimp/Crimp Attachment For RG58 Cable FMCN1149](#)

URL: <https://www.fairviewmicrowave.com/bnc-male-rg58-connector-fmcn1149-p.aspx>

The information contained in this document is accurate to the best of our knowledge and representative of the part described herein. It may be necessary to make modifications to the part and/or the documentation of the part, in order to implement improvements. Fairview Microwave reserves the right to make such changes as required. Unless otherwise stated, all specifications are nominal. Fairview Microwave does not make any representation or warranty regarding the suitability of the part described herein for any particular purpose, and Fairview Microwave does not assume any liability arising out of the use of any part or documentation.

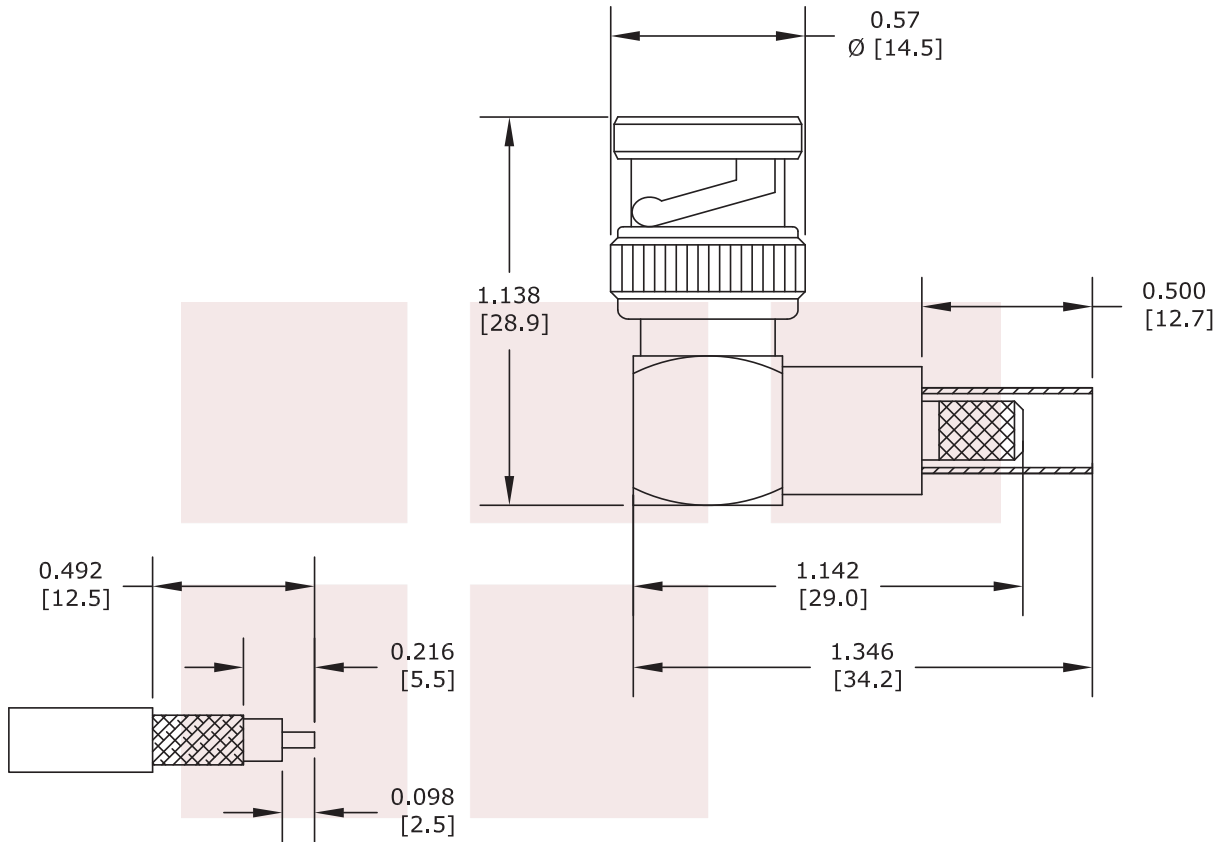

STRIPPING DIMENSIONS

ASSEMBLY PROCEDURES

1. STRIP CABLE AS SHOWN. SLIDE FERRULE OVER CABLE & CRIMP CONTACT TO CENTER CONDUCTOR.
2. INSTALL CABLE INTO BODY. PUSH CABLE FORWARD UNTIL CONTACT IS IN THE CORRECT POSITION.
3. CRIMP FERRULE

CRIMP SIZE REQUIRED

CONTACT: .071" HEX CRIMP TOOL
 FERRULE: .216" HEX CRIMP TOOL

FAIRVIEW MICROWAVE INC. ALLEN, TX 75013 WWW.FAIRVIEWMICROWAVE.COM		NOTES: 1. UNLESS OTHERWISE SPECIFIED ALL DIMENSIONS ARE NOMINAL. 2. ALL SPECIFICATIONS ARE SUBJECT TO CHANGE WITHOUT NOTICE AT ANY TIME. 3. DIMENSIONS ARE IN INCHES [mm].			
TITLE RA BNC Male Connector Crimp/Crimp Attachment For RG58 Cable	DWG NO FMCN1149	CAGE CODE 3FKR5			
CAD FILE 071916	SHEET	SCALE N/A	SIZE A	2233	