

BMA Jack Slide-On Connector Crimp/Solder Attachment 2 Hole Flange For RG316, RG174, LMR-100 Cable

BMA jack slide-on 2 hole flange mount connector with crimp/solder attachment for RG316, RG174 and LMR-100, part number FMCN1206, from Fairview Microwave is in-stock and ships same day. This BMA jack connector operates up to a maximum frequency of 12.4 GHz and offers good VSWR of 1.34:1. This blind mate connector is ideal for applications without direct visual or tactile access to the connection point, for example, when two circuit boards need to be mated. Fairview's FMCN1206 2 hole flange BMA connector enables designers to make external connections on product enclosures, and can be used in a variety of other rack mount and panel mount applications.

Fairview's BMA jack 2 hole flange connector FMCN1206 datasheet specifications and outline drawing are shown in this PDF below. Our extensive offering of RF, microwave and millimeter wave connectors allows designers to configure and customize their signal connections however they like. From providing an I/O for a board design to creating a custom cable assembly configuration, Fairview Microwave has a connector solution to meet your needs. Fairview Microwave also has the expertise to build your custom cable assemblies for you and ship them same-day.

Electrical Specifications

Description	Min	Typ	Max	Units
Frequency Range	DC		12.4	GHz
VSWR			1.34:1	
Insertion Loss			0.1	dB
Operating Voltage (AC)			335	Vrms
DWV (AC)			1,000	Vrms
Insulation Resistance	5,000			MOhms

Mechanical Specifications

Size	
Length	0.97 in [24.64 mm]
Width/Dia.	0.75 in [19.05 mm]
Weight	0.0155 lbs [7.03 g]
Mating Cycles	1,000 Cycles

Material Specifications

Description	Material	Plating
Contact	Beryllium Copper	Gold
Insulation	PTFE	
Outer Conductor	Beryllium Copper	Gold
Body	Brass	Tri-Metal

Mechanical Specification Notes:

Recommended axial float mount for best electrical performance: 0.51 +/- 0.25 mm (.020" +/- .010)



Configuration:

- Slide-On BMA Jack Connector
- 50 Ohms
- Straight Body Geometry
- RG316, RG174, LMR-100 Interface Type
- Crimp/Solder Attachment
- 2 Hole Flange

Features:

- Operating Frequency of 12.4 GHz Max.
- Good VSWR of 1.34:1
- Blind Mate Connector
- Gold Plated Beryllium Copper Contact
- Low-Engagement Force
- Radial and Axial Float Versions

Applications:

- General Purpose Test
- Rack and Panel Mount Applications
- Custom Cable Assemblies
- Phased Array Systems
- Blind Mating
- RF Backplanes
- Rack and Panel
- Base Stations
- Test I/O

Fairview Microwave
1130 Junction Dr. #100
Allen, TX 75013
Tel: 1-800-715-4396 / (972) 649-6678
Fax: (972) 649-6689
www.fairviewmicrowave.com
sales@fairviewmicrowave.com

Environmental Specifications

Temperature

Operating Range -55 to +125 deg C

Compliance Certifications (see [product page](#) for current document)

Plotted and Other Data

Notes:

BMA Jack Slide-On Connector Crimp/Solder Attachment 2 Hole Flange For RG316, RG174, LMR-100 Cable from Fairview Microwave is in-stock and available to ship same-day. All of our RF/microwave products are available off-the-shelf from our ISO 9001:2008 certified facilities in Allen, Texas. Fairview Microwave is RF on-demand.

For additional information on this product, please click the following link: [BMA Jack Slide-On Connector Crimp/Solder Attachment 2 Hole Flange For RG316, RG174, LMR-100 Cable FMCN1206](#)

URL: <https://www.fairviewmicrowave.com/bma-jack-slide-on-rg316-rg174-lmr-100-connector-fmcn1206-p.aspx>

The information contained in this document is accurate to the best of our knowledge and representative of the part described herein. It may be necessary to make modifications to the part and/or the documentation of the part, in order to implement improvements. Fairview Microwave reserves the right to make such changes as required. Unless otherwise stated, all specifications are nominal. Fairview Microwave does not make any representation or warranty regarding the suitability of the part described herein for any particular purpose, and Fairview Microwave does not assume any liability arising out of the use of any part or documentation.

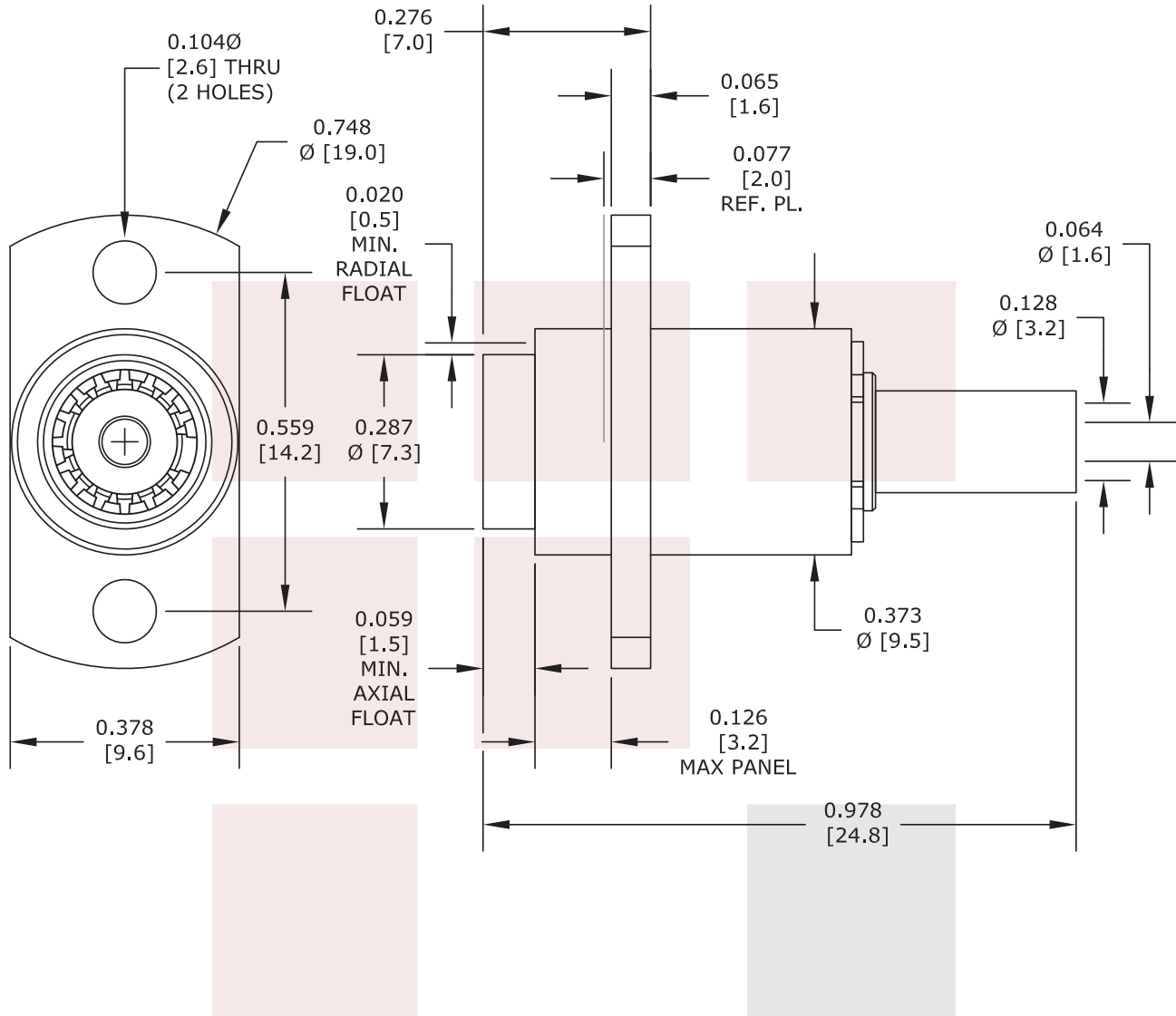

STANDARD TOLERANCES	
.X	±0.2
.XX	±0.1
.XXX	±0.05

*STANDARD TOLERANCES APPLY ONLY TO DIMENSIONS IN INCHES

FAIRVIEW MICROWAVE INC. ALLEN, TX 75013 WWW.FAIRVIEWMICROWAVE.COM		NOTES: 1. UNLESS OTHERWISE SPECIFIED ALL DIMENSIONS ARE NOMINAL. 2. ALL SPECIFICATIONS ARE SUBJECT TO CHANGE WITHOUT NOTICE AT ANY TIME. 3. DIMENSIONS ARE IN INCHES [mm].			
TITLE BMA Jack Slide-On Connector Crimp/Solder Attachment 2 Hole Flange For RG316, RG174, LMR-100 Cable		DWG NO FMCN1206		CAGE CODE 3FKR5	
CAD FILE	022717	SHEET	SCALE	N/A	SIZE A 2233

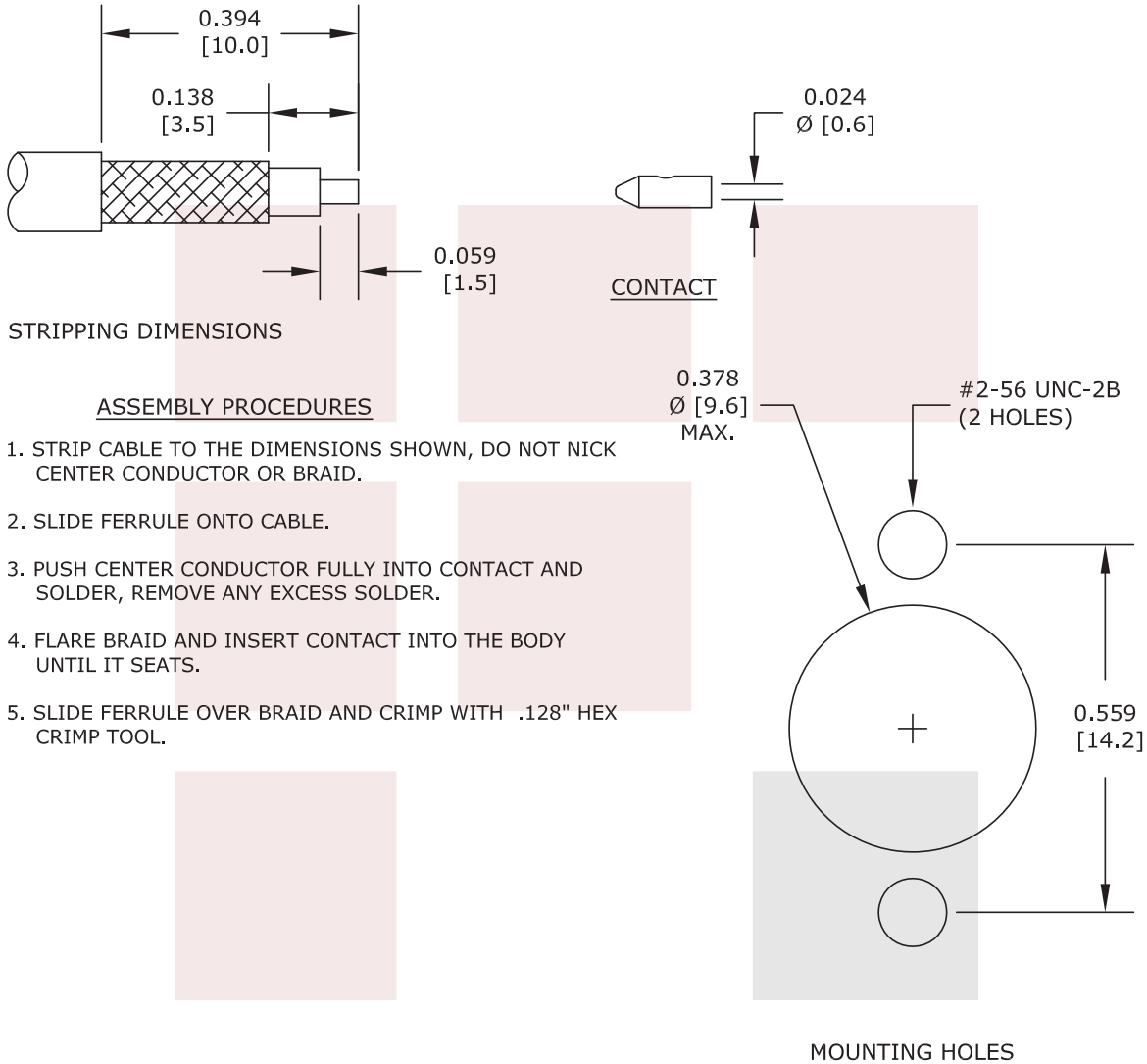

STANDARD TOLERANCES	
.X	±0.2
.XX	±0.1
.XXX	±0.05

*STANDARD TOLERANCES APPLY ONLY TO DIMENSIONS IN INCHES

FAIRVIEW MICROWAVE INC. ALLEN, TX 75013 WWW.FAIRVIEWMICROWAVE.COM		NOTES: 1. UNLESS OTHERWISE SPECIFIED ALL DIMENSIONS ARE NOMINAL. 2. ALL SPECIFICATIONS ARE SUBJECT TO CHANGE WITHOUT NOTICE AT ANY TIME. 3. DIMENSIONS ARE IN INCHES [mm].			
TITLE BMA Jack Slide-On Connector Crimp/Solder Attachment 2 Hole Flange For RG316, RG174, LMR-100 Cable		DWG NO FMCN1206		CAGE CODE 3FKR5	
CAD FILE	022717	SHEET	SCALE	N/A	SIZE A 2233