

## 2.2-5 Male Low PIM Quick Lock Connector Solder Attachment for FM-1/4SFHC, SPP-250-LLPL, SPO-250, SPF-250 Cable

2.2-5 male quick lock connector with solder/solder attachment for FM-1/4SFHC, SPP-250-LLPL, SPO-250 and SPF-250, part number FMCN1717, from Fairview Microwave is in-stock and ships same day. This 2.2-5 male connector operates up to a maximum frequency of 6 GHz and offers excellent VSWR of 1.25:1. The 2.2-5 male connector also has low passive intermodulation (PIM) of -163 dBc.

Fairview's 2.2-5 male connector FMCN1717 datasheet specifications and outline drawing are shown in this PDF below. Our extensive offering of RF, microwave and millimeter wave connectors allows designers to configure and customize their signal connections however they like. From providing an I/O for a board design to creating a custom cable assembly configuration, Fairview Microwave has a connector solution to meet your needs. Fairview Microwave also has the expertise to build your custom cable assemblies for you and ship them same-day.

### Electrical Specifications

Description	Min	Typ	Max	Units
Frequency Range	DC		6	GHz
VSWR			1.25:1	
Passive Intermodulation			-163	dBc
DWV (AC)			750	Vrms

### Performance by Frequency

Description	F1	F2	F3	F4	F5	Units
Freq. Range	DC to 3	3 to 6				GHz
VSWR, Max	1.15:1	1.25:1				

### Mechanical Specifications

<b>Size</b>	
Length	0.89 in [22.61 mm]
Width/Dia.	0.71 in [18.03 mm]
Weight	0.03 lbs [13.61 g]

### Material Specifications

Description	Material	Plating
Contact	Brass	Silver
Insulation	PTFE	
Body	Brass	Tri-Metal
Coupling Nut	Brass	Tri-Metal
O-Ring	Silicone	



### Configuration:

- Quick Lock 2.2-5 Male Connector
- 50 Ohms
- Straight Body Geometry
- FM-1/4SFHC, SPP-250-LLPL, SPO-250, SPF-250 Interface Type
- Solder/Solder Attachment
- Low PIM Design

### Features:

- Operating Frequency of 6 GHz Max.
- Excellent VSWR of 1.25:1
- PIM levels better than -163 dBc
- Silver Plated Brass Contact

### Applications:

- General Purpose Test
- Wireless Communications
- Custom Cable Assemblies
- Low PIM Applications

Fairview Microwave  
 301 Leora Ln., Suite 100  
 Lewisville, TX 75056  
 Tel: 1-800-715-4396 / (972) 649-6678  
 Fax: (972) 649-6689  
[www.fairviewmicrowave.com](http://www.fairviewmicrowave.com)  
[sales@fairviewmicrowave.com](mailto:sales@fairviewmicrowave.com)

**Environmental Specifications**

**Temperature**

Operating Range -40 to +155 deg C

**Compliance Certifications** (see [product page](#) for current document)

**Plotted and Other Data**

Notes:

2.2-5 Male Low PIM Quick Lock Connector Solder Attachment for FM-1/4SFHC, SPP-250-LLPL, SPO-250, SPF-250 Cable from Fairview Microwave is in-stock and available to ship same-day. All of our RF/microwave products are available off-the-shelf from our ISO 9001:2008 certified facilities in Lewisville, Texas. Fairview Microwave is RF on-demand.

For additional information on this product, please click the following link: [2.2-5 Male Low PIM Quick Lock Connector Solder Attachment for FM-1/4SFHC, SPP-250-LLPL, SPO-250, SPF-250 Cable FMCN1717](#)

URL: <https://www.fairviewmicrowave.com/invalid-alias-male-quick-lock-spp-250-llpl-spo-250-spf-250-connector-fmcn1717-p.aspx>

The information contained in this document is accurate to the best of our knowledge and representative of the part described herein. It may be necessary to make modifications to the part and/or the documentation of the part, in order to implement improvements. Fairview Microwave reserves the right to make such changes as required. Unless otherwise stated, all specifications are nominal. Fairview Microwave does not make any representation or warranty regarding the suitability of the part described herein for any particular purpose, and Fairview Microwave does not assume any liability arising out of the use of any part or documentation.

REVISIONS			
REV.	DESCRIPTION	DATE	APPROVED
A	INITIAL RELEASE	1/12/2021	S.ELLIS

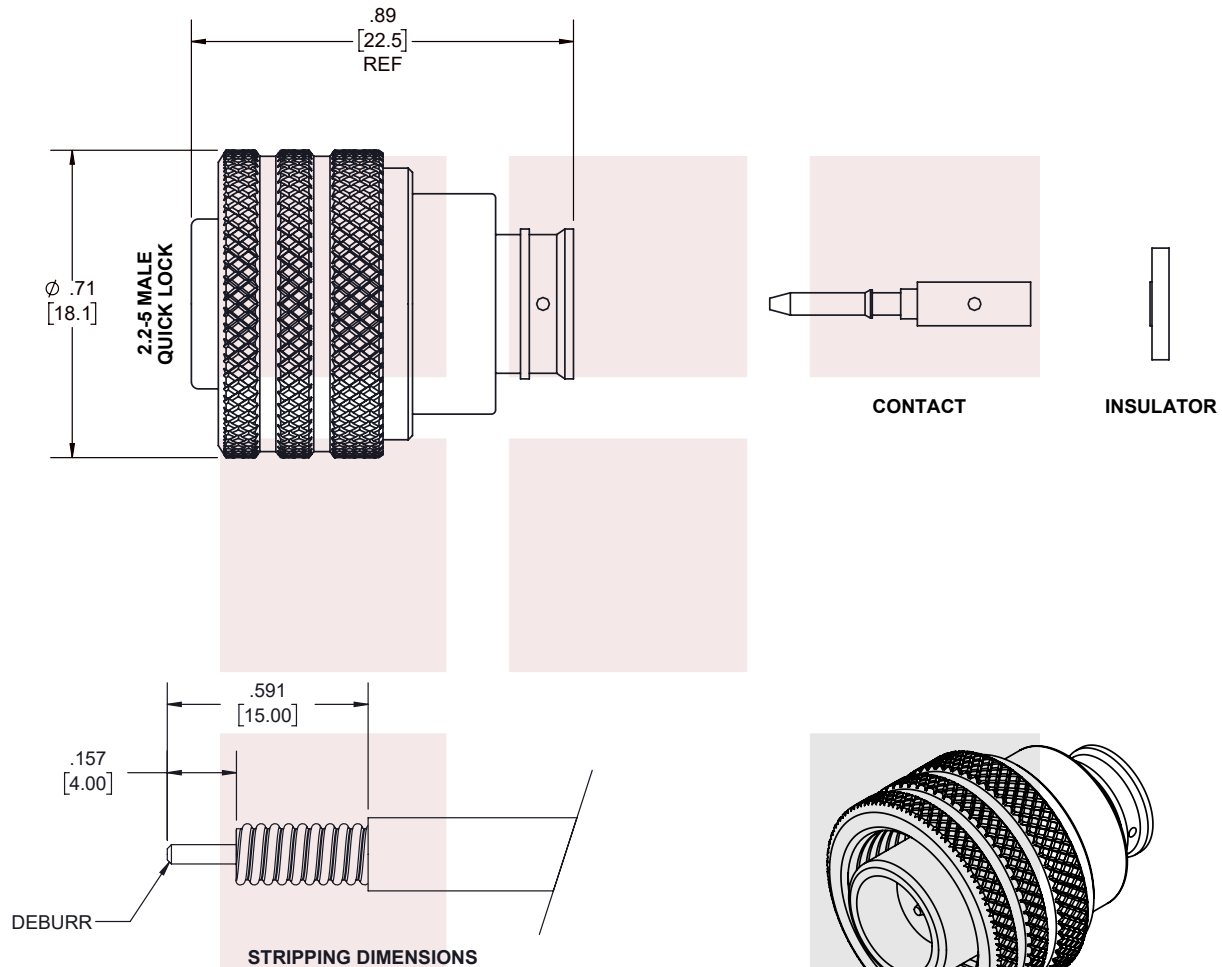

- NOTES:
- CABLE ATTACHMENT:
    - OUTER: SOLDER.
    - INNER: SOLDER.

THESE COMMODITIES, TECHNOLOGY OR SOFTWARE WERE EXPORTED FROM THE UNITED STATES IN ACCORDANCE WITH THE EXPORT ADMINISTRATION REGULATIONS. DIVERSION CONTRARY TO U.S. LAW PROHIBITED.

TITLE  
2.2-5 Male Low PIM Quick Lock Connector Solder Attachment for FM-1/4SFHC, SPP-250-LLPL, SPO-250, SPF-250 Cable

UNLESS OTHERWISE SPECIFIED LEADING DIMENSIONS ARE INCHES  
DIMENSIONS IN [ ] ARE MILLIMETERS

TOLERANCES: CABLE LENGTH (L) TOLERANCES:

.X = ±.2 [5.08]	FRACTIONS	L ≤ 12 [305] = +1 [25] / -0
.XX = ±.02 [.51]	± 1/32	12 [305] < L ≤ 60 [1524] = +2 [51] / -0
.XXX = ±.005 [.13]	ANGLES ± 1°	60 [1524] < L ≤ 120 [3048] = +4 [102] / -0
		120 [3048] < L ≤ 300 [7620] = +6 [152] / -0
		300 [7620] < L = +5%L / -0

THIRD-ANGLE PROJECTION

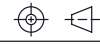

THE INFORMATION AND DESIGN IN THIS DOCUMENT IS THE PROPERTY OF FAIRVIEW MICROWAVE CORPORATION. ALL RIGHTS RESERVED.

SHEET 1 OF 1

ALL DIMENSIONS SHOWN ARE FOR REFERENCE ONLY.

SCALE N/A

SIZE A	CAGE CODE 3FKR5	DRAWN BY K.DANG	ITEM NO. FMCN1717	REV A
-----------	--------------------	--------------------	----------------------	----------

T-Rev.D