

## BNC Female Bulkhead Connector Clamp/Solder Attachment For FM-SR141ALTN, FM-SR141TB, FM-SR141TBJ, RG402

BNC female bulkhead connector with clamp/solder attachment for FM-SR141ALTN, FM-SR141TB, FM-SR141TBJ and RG402, part number FMCN1911, from Fairview Microwave is in-stock and ships same day. Fairview's FMCN1911 bulkhead BNC connector enables designers to make external connections on product enclosures, and can be used in a variety of other rack mount and panel mount applications.

Fairview's BNC female bulkhead connector FMCN1911 datasheet specifications and outline drawing are shown in this PDF below. Our extensive offering of RF, microwave and millimeter wave connectors allows designers to configure and customize their signal connections however they like. From providing an I/O for a board design to creating a custom cable assembly configuration, Fairview Microwave has a connector solution to meet your needs. Fairview Microwave also has the expertise to build your custom cable assemblies for you and ship them same-day.

### Mechanical Specifications

<b>Size</b>	
Length	1.15 in [29.21 mm]
Width/Dia.	0.688 in [17.48 mm]
Height	0.688 in [17.48 mm]
Weight	0.048 lbs [21.77 g]

### Material Specifications

Description	Material	Plating
Body	Brass	Nickel

**Compliance Certifications** (see [product page](#) for current document)

### Plotted and Other Data

Notes:

BNC Female Bulkhead Connector Clamp/Solder Attachment For FM-SR141ALTN, FM-SR141TB, FM-SR141TBJ, RG402 from Fairview Microwave is in-stock and available to ship same-day. All of our RF/microwave products are available off-the-shelf from our ISO 9001:2008 certified facilities in Lewisville, Texas. Fairview Microwave is RF on-demand.

For additional information on this product, please click the following link: [BNC Female Bulkhead Connector Clamp/Solder Attachment For FM-SR141ALTN, FM-SR141TB, FM-SR141TBJ, RG402 FMCN1911](#)

URL: <https://www.fairviewmicrowave.com/bnc-female-standard-pe-sr402al-pe-sr402fl-rg402-connector-fmcn1911-p.aspx>

The information contained in this document is accurate to the best of our knowledge and representative of the part described herein. It may be necessary to make modifications to the part and/or the documentation of the part, in order to implement improvements. Fairview Microwave reserves the right to make such changes as required. Unless otherwise stated, all specifications are nominal. Fairview Microwave does not make any representation or warranty regarding the suitability of the part described herein for any particular purpose, and Fairview Microwave does not assume any liability arising out of the use of any part or documentation.



### Configuration:

- BNC Female Connector
- 50 Ohms
- Straight Body Geometry
- FM-SR141ALTN, FM-SR141TB, FM-SR141TBJ, RG402 Interface Type
- Clamp/Solder Attachment
- Bulkhead

### Applications:

- General Purpose Test
- Rack and Panel Mount Applications
- Custom Cable Assemblies

Fairview Microwave  
301 Leora Ln., Suite 100  
Lewisville, TX 75056  
Tel: 1-800-715-4396 / (972) 649-6678  
Fax: (972) 649-6689  
[www.fairviewmicrowave.com](http://www.fairviewmicrowave.com)  
[sales@fairviewmicrowave.com](mailto:sales@fairviewmicrowave.com)

REVISIONS			
REV.	DESCRIPTION	DATE	APPROVED
A	INITIAL RELEASE	06/07/22	AGANWANI

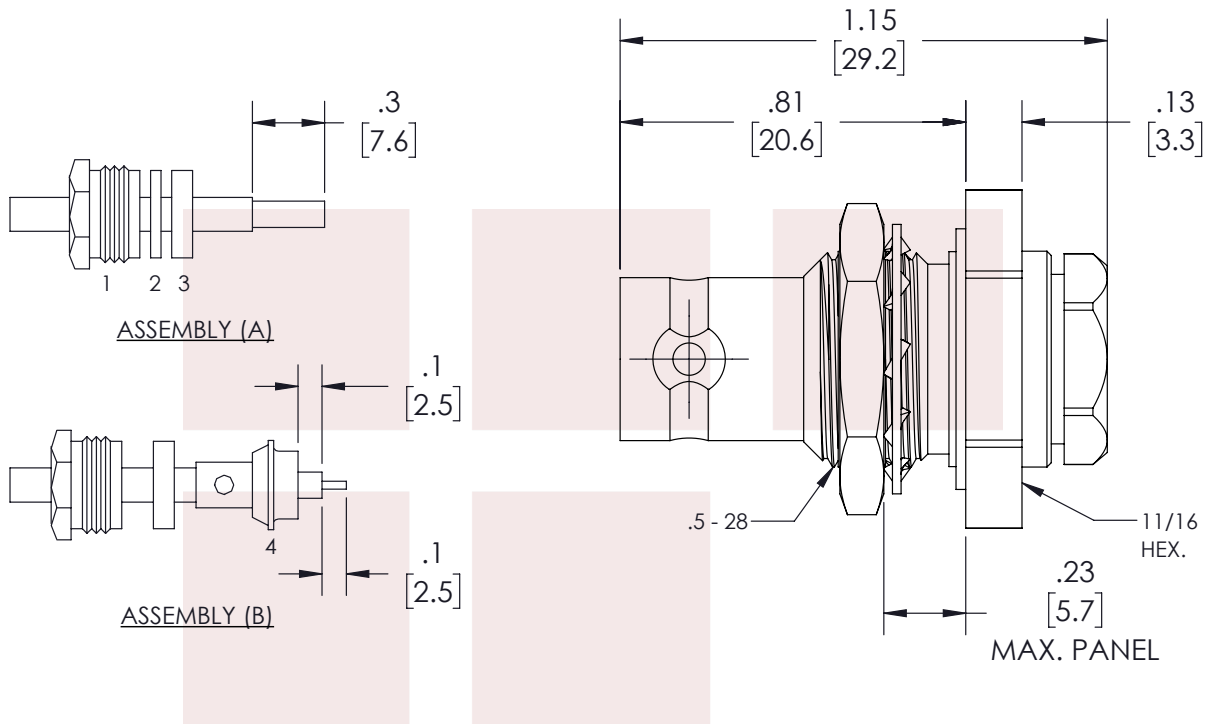

### ASSEMBLY PROCEDURES

1. SLIDE CLAMP NUT (1), WASHER (2) & GASKET (3) OVER CABLE. STRIP CABLE AS SHOWN IN ASSEMBLY (A). DO NOT CUT DIELECTRIC.
2. SLIDE ADAPTER (4) OVER CABLE UNTIL ADAPTER (4) BOTTOMS ON OUTER CONDUCTOR. SOLDER ADAPTER (4) TO OUTER CONDUCTOR USING MINIMUM HEAT.
3. STRIP CABLE AS SHOWN IN ASSEMBLY (B). SOLDER CONTACT TO CENTER CONDUCTOR. SLIDE ASSEMBLY FORWARD & TIGHTEN TO BODY.

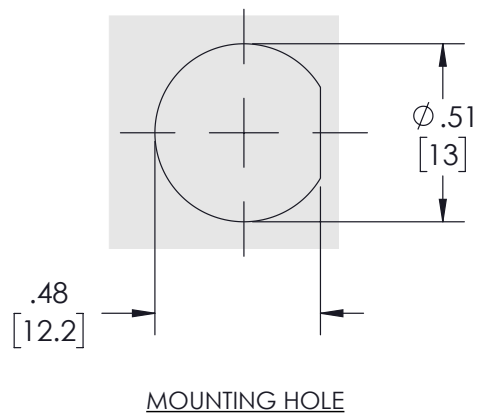

THESE COMMODITIES, TECHNOLOGY OR SOFTWARE WERE EXPORTED FROM THE UNITED STATES IN ACCORDANCE WITH THE EXPORT ADMINISTRATION REGULATIONS. DIVERSION CONTRARY TO U.S. LAW PROHIBITED.

<p><b>Fairview Microwave</b> an INFINIT<sup>®</sup> brand</p>	UNLESS OTHERWISE SPECIFIED LEADING DIMENSIONS ARE INCHES DIMENSIONS IN [ ] ARE MILLIMETERS		THIRD-ANGLE PROJECTION 	
	TOLERANCES:		CABLE LENGTH (L) TOLERANCES:	
TITLE  BNC Female Bulkhead Connector Clamp/Solder Attachment For FM-SR141ALTN, FM-SR141TB, FM-SR141TBJ, RG402	.X = ±.2 [5.08]	FRACTIONS ± 1/32	L ≤ 12 [305] = +1 [25] / -0	THE INFORMATION AND DESIGN IN THIS DOCUMENT IS THE PROPERTY OF FAIRVIEW MICROWAVE CORPORATION. ALL RIGHTS RESERVED. SHEET 1 OF 1
	.XX = ±.02 [.51]	ANGLES ± 1°	12 [305] < L ≤ 60 [1524] = +2 [51] / -0 60 [1524] < L ≤ 120 [3048] = +4 [102] / -0 120 [3048] < L ≤ 300 [7620] = +6 [152] / -0 300 [7620] < L = +5%L / -0	
ALL DIMENSIONS SHOWN ARE FOR REFERENCE ONLY.				SCALE N/A
SIZE A	CAGE CODE 3FKR5	DRAWN BY VTHANGARAJ	ITEM NO. FMCN1911	REV A

T-Rev.D