

SPECIFICATIONS

ELECTRICAL:

FREQUENCY: 0-3 GHZ
 VSWR @ 1 GHZ: 1.15:1 MAX
 VSWR @ 2.4 GHZ: 1.2:1 MAX
 VSWR @ 3 GHZ: 1.25 MAX
 POWER (AVG) 25 WATTS @ 25 DEG C
 POWER (PEAK) 2000 WATTS
 ATTENUATION ACCURACY: GREATER OF
 +/-0.5DB OR 3%
 IMPEDANCE: 50 OHMS

ENVIRONMENTAL:

TEMP: -55 C TO +125 C

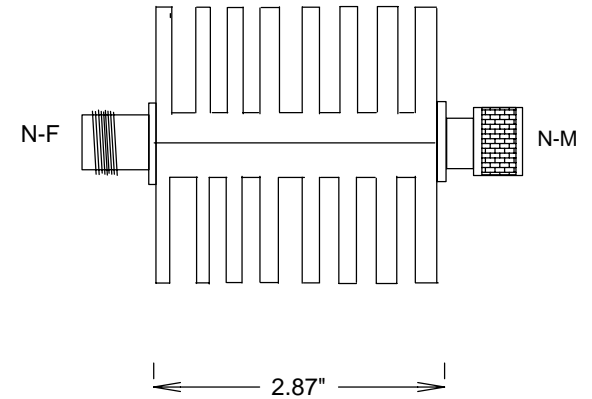
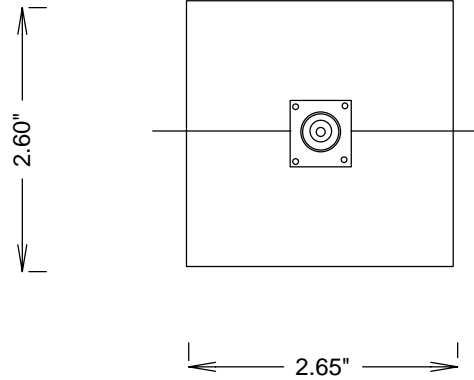

S. M. ELECTRONICS

FAIRVIEW, TX 75069 WWW.SMELECTRONICS.US

TITLE

ATTENUATORS N 25 WATTS 3GHZ

SIZE	CAGE CODE	DWG NO	REV
A	3FKR5	SA3N25-XX	--
SCALE		SHEET	