

SMA-F PANEL .141 SR TRIM/SOLDER

SC3533

SPECIFICATIONS

ELECTRICAL:

FREQUENCY: 0-18 GHZ
 IMPEDANCE: 50 OHMS

MECHANICAL:

MATERIAL BODY: Au PLATED STAINLESS STEEL
 CENTER CONTACT: BeCu Au PLATED MIL-G-45204
 INSULATOR: TEFLON
 INTERFACE: MIL-STD-883A
 OP. TEMP RANGE: -55°C to +155°C
 ROHS COMPLIANT

ASSEMBLY

TRIM CABLE AS SHOWN,
 INSERT CABLE INTO SMA BODY,
 SOLDER CONNECTOR BODY TO CABLE JACKET

SMA-F

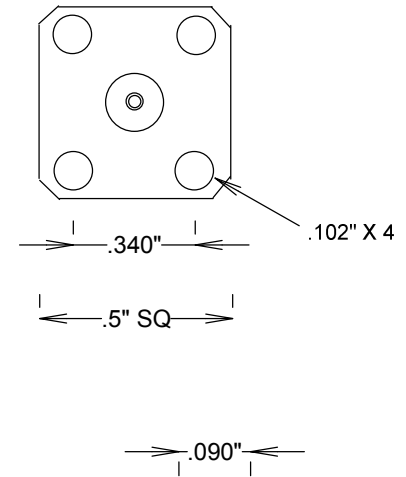
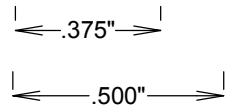
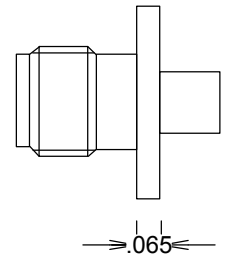

STRIPPING DIMENSIONS

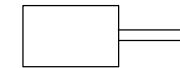

				FAIRVIEW MICROWAVE INC.			
				ALLEN, TX 75013 WWW.FAIRVIEWMICROWAVE.COM			
				TITLE			
				SMA-F PANEL .141 SR TRIM/SOLDER			
SIZE	CAGE CODE	DWG NO				REV	
A	3FKR5	SC3533				--	
SCALE						SHEET	