

SMA-F PANEL POST RIGHT ANGLE

SC3787

SPECIFICATIONS

ELECTRICAL:

FREQUENCY: 0-12 GHZ
IMPEDANCE: 50 OHMS

MECHANICAL:

MATERIAL BODY: PASSIVATED STAINLESS STEEL
CENTER CONTACT: BeCu
CONTACT PLATING: Au PER MIL-G-45204
INSULATOR: TEFLON
INTERFACE: MIL-STD-348A
ROHS COMPLAINT
OP. TEMP RANGE: -55°C to +155°C

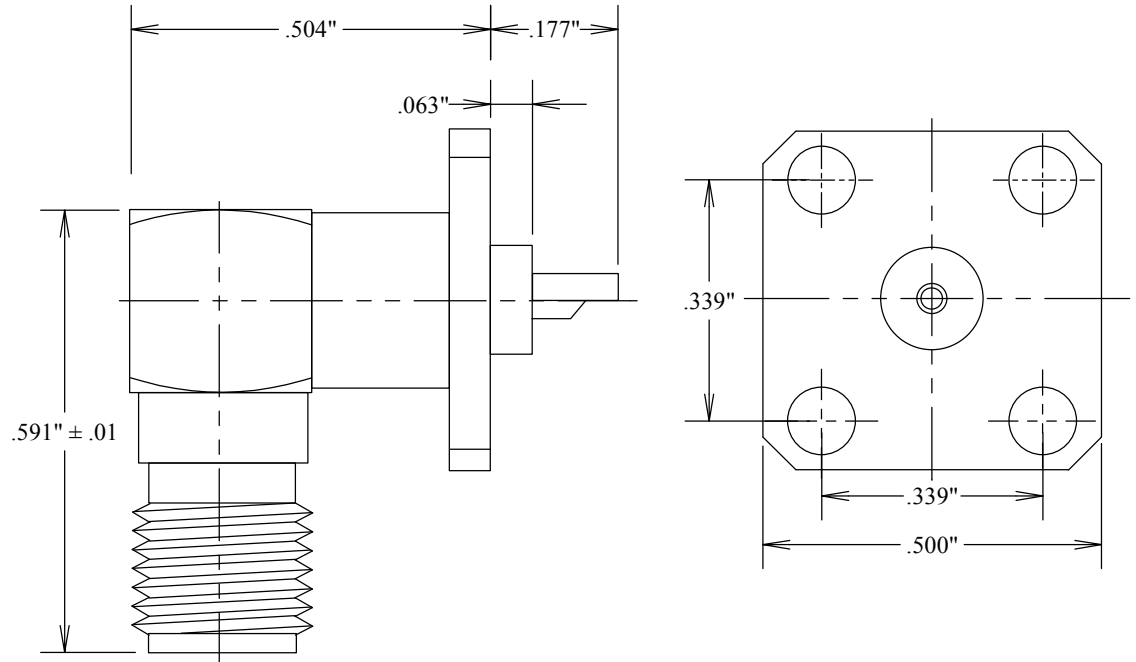

FAIRVIEW MICROWAVE INC.

ALLEN, TX 75013 WWW.FAIRVIEWMICROWAVE.COM

TITLE

SMA-F PANEL POST RIGHT ANGLE

SIZE CAGE CODE DWG NO

A

3FKR5

SC3787

REV

--

SCALE

SHEET