

BNC-F BULKHEAD RG55 RG142 CRIMP

SC6017

SPECIFICATIONS

ELECTRICAL:

FREQUENCY: 0-4 GHZ
 VSWR 1.5:1 MAX
 IMPEDANCE: 50 OHMS
 OP. TEMP RANGE: -55C- +120C

MECHANICAL:

MATERIAL BODY: BRASS, NICKLE PLATED
 CENTER CONTACT: BRASS
 CONTACT PLATING: Si
 INSULATOR: TEFLON
 INTERFACE: MIL-STD-348A
 ROHS COMPLIANT

ASSEMBLY INSTRUCTIONS:

CABLE ATTACHMENT: OUTER - CRIMP, INNER - SOLDER/CRIMP
 .071 HEX CRIMP TOOL FOR CONTACT
 .216 HEX CRIMP TOOL FOR FERRULE

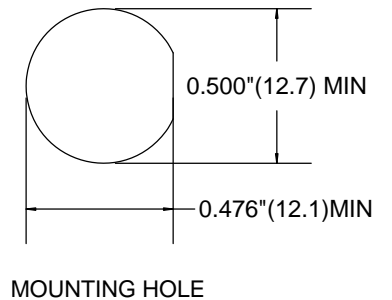
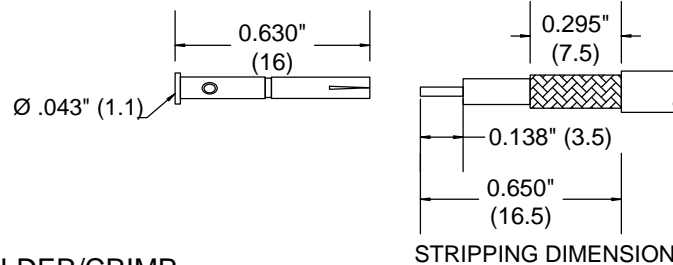
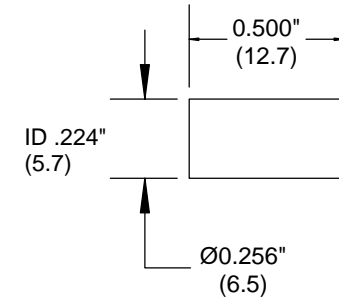
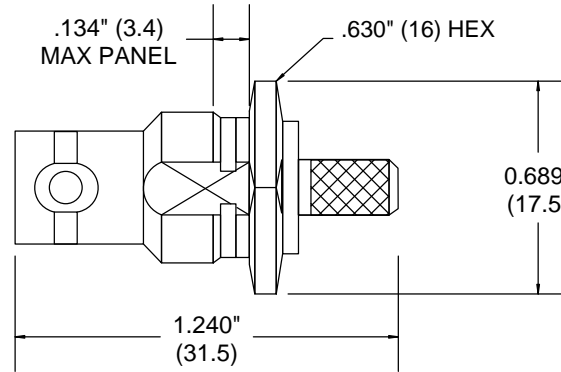

FAIRVIEW MICROWAVE INC.

ALLEN, TX 75013 WWW.FAIRVIEWMICROWAVE.COM

TITLE

BNC-F BULKHEAD RG55 RG142 CRIMP

SIZE	CAGE CODE	DWG NO	REV
A	3FKR5	SC6017	--
SCALE		SHEET	

ALL DIMENSIONS IN inches(MM) Typical