

**RA N Male Connector Crimp/Solder Attachment For LMR-200 Cable**

**Configuration**

Connector N Male

**Electrical Specifications\***

| Description     | Min | Typ | Max | Units |
|-----------------|-----|-----|-----|-------|
| Frequency Range | DC  |     | 11  | GHz   |
| Impedance       |     | 50  |     | Ohms  |

\* Values at 25°C, sea level

**Mechanical Specifications**

**Size**

Length 1.103 in [28.02 mm]  
 Width/Dia. 0.9 in [22.86 mm]

**Connector**

Type N Male  
 Contact Material and Plating Brass, Gold  
 Coupling Nut Material and Plating Brass, Nickel  
 Body Material and Plating Brass, Nickel  
 Dielectric Type PTFE

**Compliance Certifications** (visit [www.FairviewMicrowave.com](http://www.FairviewMicrowave.com) for current document)

RoHS Compliant Yes

**Plotted and Other Data**

Notes:  
 • Values at +25 °C, sea level

RA N Male Connector Crimp/Solder Attachment For LMR-200 Cable from Fairview Microwave is in-stock and available to ship same-day. All of our RF/microwave products are available off-the-shelf from our ISO 9001:2008 certified facilities in Allen, Texas. Fairview Microwave is RF on-demand.

For additional information on this product, please click the following link: [RA N Male Connector Crimp/Solder Attachment For LMR-200 Cable SC9188](#)

URL: <http://www.fairviewmicrowave.com/n-male-standard-lmr-200-connector-sc9188-p.aspx>

The information contained in this document is accurate to the best of our knowledge and representative of the part described herein. It may be necessary to make modifications to the part and/or the documentation of the part, in order to implement improvements. Fairview Microwave reserves the right to make such changes as required. Unless otherwise stated, all specifications are nominal. Fairview Microwave does not make any representation or warranty regarding the suitability of the part described herein for any particular purpose, and Fairview Microwave does not assume any liability arising out of the use of any part or documentation.



**Features:**

- Interface: LMR-200
- Attachment: Crimp/Solder
- Body Style: Right Angle

Fairview Microwave  
 1130 Junction Dr. #100  
 Allen, TX 75013  
 Tel: 1-800-715-4396 / (972) 649-6678  
 Fax: (972) 649-6689  
[www.fairviewmicrowave.com](http://www.fairviewmicrowave.com)  
[sales@fairviewmicrowave.com](mailto:sales@fairviewmicrowave.com)

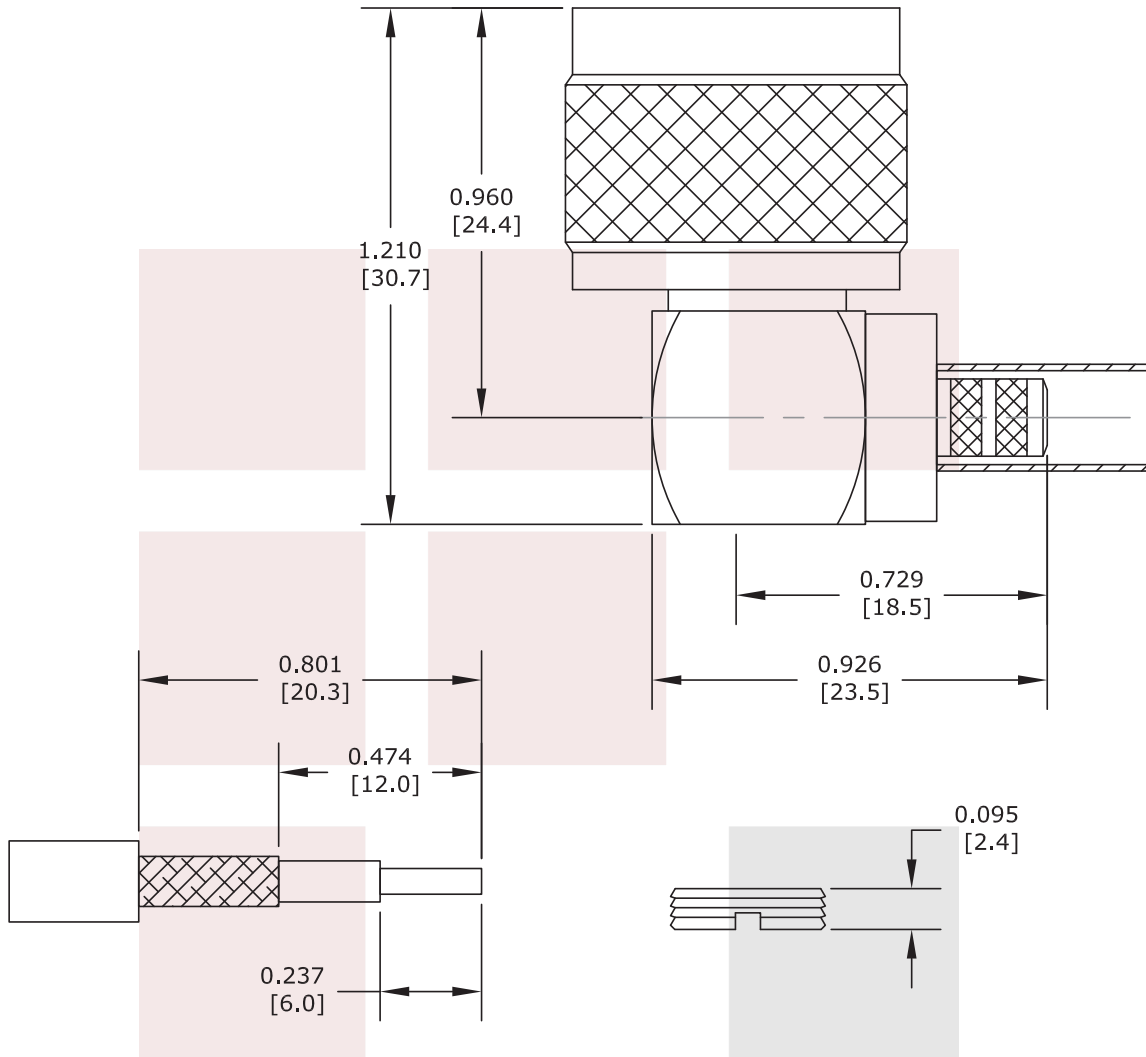

STRIPPING DIMENSIONS

CRIMP SIZE REQUIRED

CONTACT PIN: SOLDER  
 FERRULE: .213" HEX CRIMP TOOL

|                                                                             |        |                                                                                                                                                                                     |       |                    |             |
|-----------------------------------------------------------------------------|--------|-------------------------------------------------------------------------------------------------------------------------------------------------------------------------------------|-------|--------------------|-------------|
| <b>FAIRVIEW MICROWAVE INC.</b><br>ALLEN, TX 75013 WWW.FAIRVIEWMICROWAVE.COM |        | NOTES:<br>1. UNLESS OTHERWISE SPECIFIED ALL DIMENSIONS ARE NOMINAL.<br>2. ALL SPECIFICATIONS ARE SUBJECT TO CHANGE WITHOUT NOTICE AT ANY TIME.<br>3. DIMENSIONS ARE IN INCHES [mm]. |       |                    |             |
| TITLE<br>RA N Male Connector Crimp/Solder Attachment For LMR-200 Cable      |        | DWG NO<br>SC9188                                                                                                                                                                    |       | CAGE CODE<br>3FKR5 |             |
| CAD FILE                                                                    | 080814 | SHEET                                                                                                                                                                               | SCALE | N/A                | SIZE A 2233 |