

TNC/F-BNC/F BULKHEAD HERMETIC ADAPTER

SM3543

SPECIFICATIONS

ELECTRICAL

FREQUENCY: 0-4 GHZ
 IMPEDANCE: 50 OHMS
 VSWR: 1.3:1 MAX @ 4GHZ

MECHANICAL

MATERIALS BODY: NICKEL PLATED BRASS
 CONTACTS: BeCu
 CONTACT PLATING: BNC: Si, TNC: Au, MIL-G-45208
 INULATOR: PTFE
 INTERFACE: MIL-STD-348A
 HERMETIC

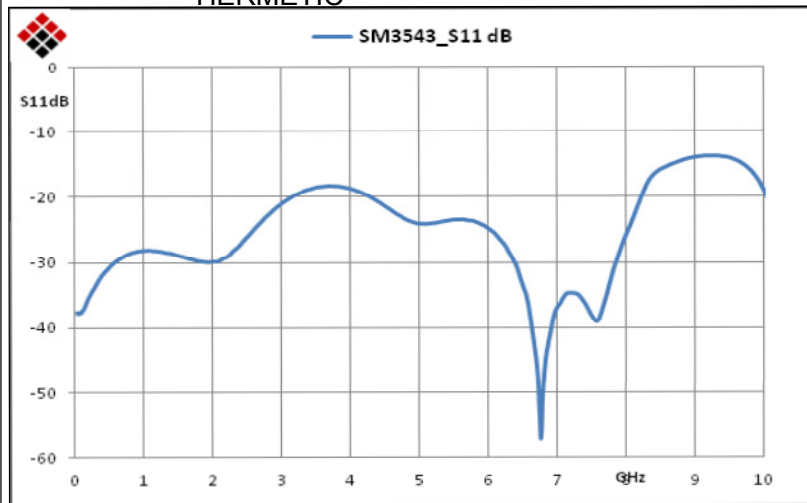
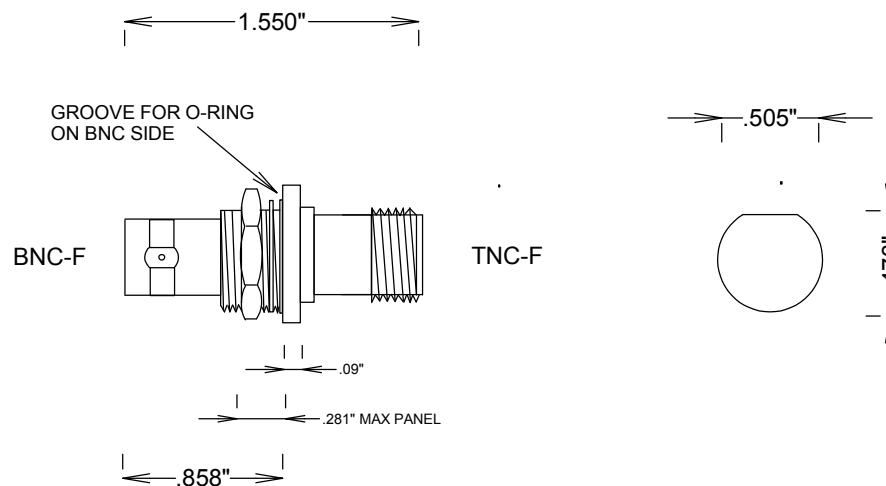

FAIRVIEW MICROWAVE INC.			
ALLEN, TX 75013 WWW.FAIRVIEWMICROWAVE.COM			
TITLE			
TNC/F-BNC/F BULKHEAD HERMETIC ADAPTER			
SIZE	CAGE CODE	DWG NO	REV
A	3FKR5	SM3543	A
SCALE		SHEET	