

SMB-BNC ADAPTERS 4GHZ

SM3630

SPECIFICATIONS

ELECTRICAL

FREQUENCY: 0-4 GHZ
 IMPEDANCE: 50 OHMS
 VSWR: 1.2:1 MAX @ 2GHZ
 1.35:1 MAX @ 4 GHZ

MECHANICAL

MATERIAL BODY: NICKEL PLATED BRASS
 MATERIAL CONTACTS: BeCu
 CONTACT PLATING: Au PER MIL-G-45204
 INSULATOR: TELFON
 INTERFACE: MIL-STD-348A
 TEMPERATURE: -65° +125°C

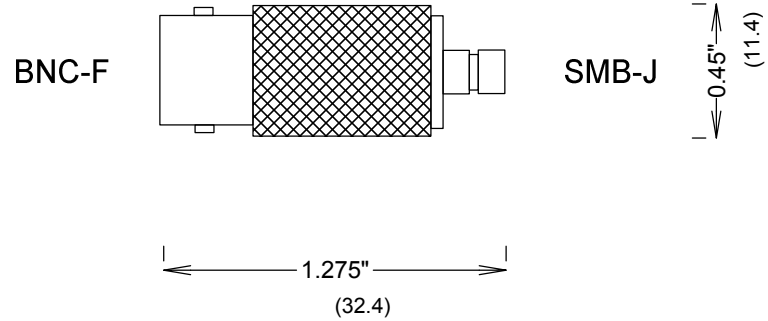

MEASUREMENTS BELOW ARE TYPICAL

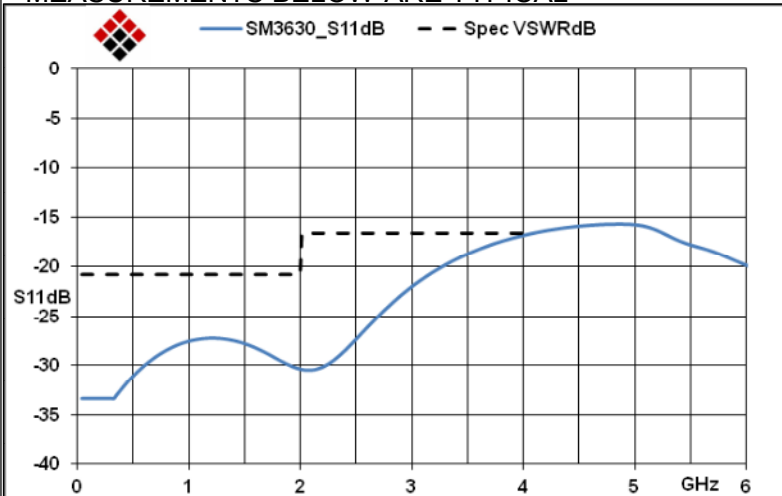

ALL DIMENSIONS IN inches(MM) Typical

FAIRVIEW MICROWAVE INC.

ALLEN, TX 75013 WWW.FAIRVIEWMICROWAVE.COM

TITLE

SMB-BNC ADAPTERS 4GHZ

SIZE	CAGE CODE	DWG NO	REV
A	3FKR5	SM3630	D
SCALE		SHEET	