

N-SMA F/F 12.4 GHZ FLANGE ADAPTER

SM4224

SPECIFICATIONS

ELECTRICAL

FREQUENCY: 0-12.4 GHZ
 IMPEDANCE: 50 OHMS
 VSWR: 1.25:1 MAX

MECHANICAL

BODY N: NICKEL PLATED BRASS
 BODY SMA: PASSIVATED STAINLESS STEEL
 CONTACTS BeCu Au PLATING MIL-G-45204
 INSULATOR: TEFLON
 INTERFACE: MIL-STD-348A
 ROHS COMPLIANT

O-RING ON SMA SIDE

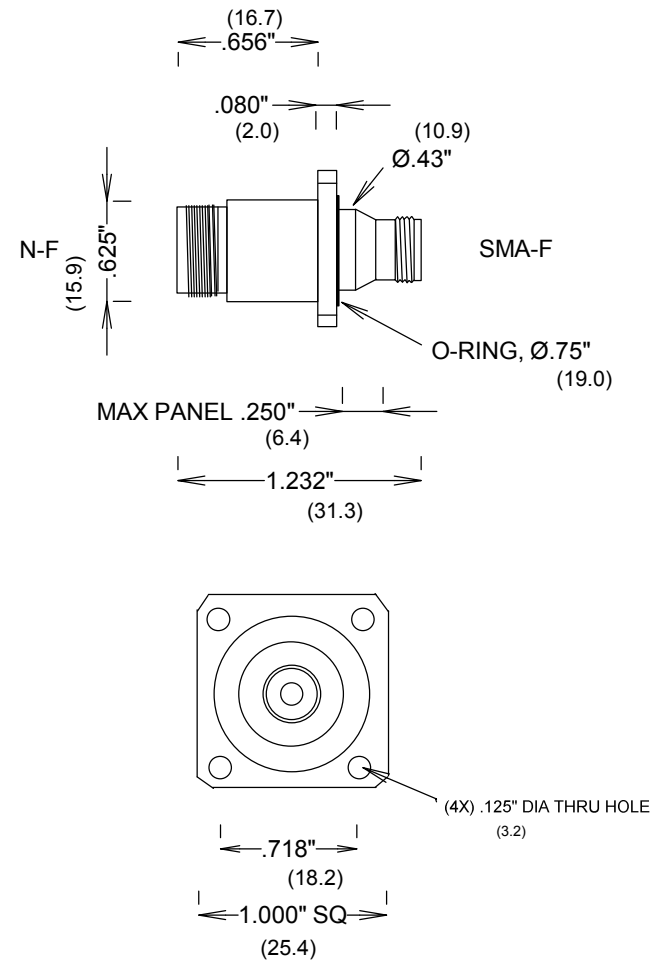

MEASUREMENTS BELOW ARE TYPICAL

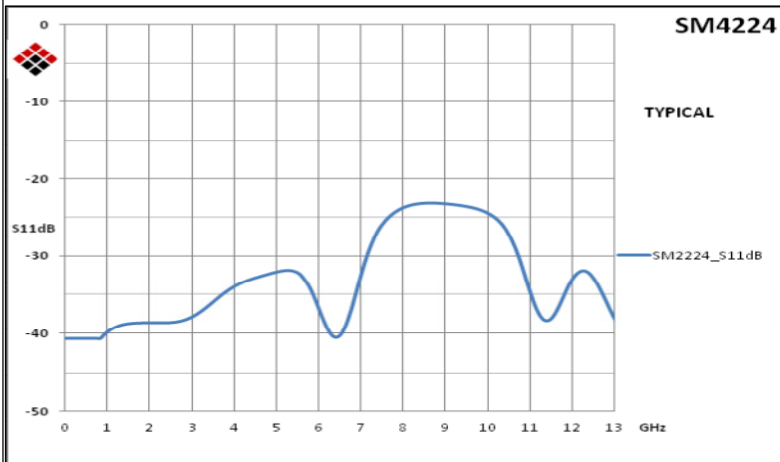

ALL DIMENSIONS IN inches(MM) Typical

FAIRVIEW MICROWAVE INC.			
ALLEN, TX 75013 WWW.FAIRVIEWMICROWAVE.COM			
TITLE N-SMA F/F 12.4 GHZ FLANGE ADAPTER			
SIZE A	CAGE CODE 3FKR5	DWG NO SM4224	REV C
SCALE		SHEET	