

# 2.92mm M .085 SEMI-RIGID

SMC292-085M

## SPECIFICATIONS

### ELECTRICAL

50 OHMS

VSWR 1.25:1 MAX @ 40 GHZ

FREQUENCY: DC-40 GHZ

### MECHANICAL

500 CYCLES MIN

4.0 INCH-OUNCES MIN CONTACT TORQUE

8-10 LBS COUPLING NUT MATING TORQUE

### ENVIRONMENTAL

-55 DEG C TO +100 DEG C

CORROSION: MIL-STD 202

VIBRATION: MIL-STD 202

### MATERIALS PASSIVATED STAINLESS STEEL

BODY: SST ASTM A484 / A582

BeCu ATSM-B-196

PASSIVATED ASTM A380

CENTER CONTACTS Au PLATED

MIL-G-45204

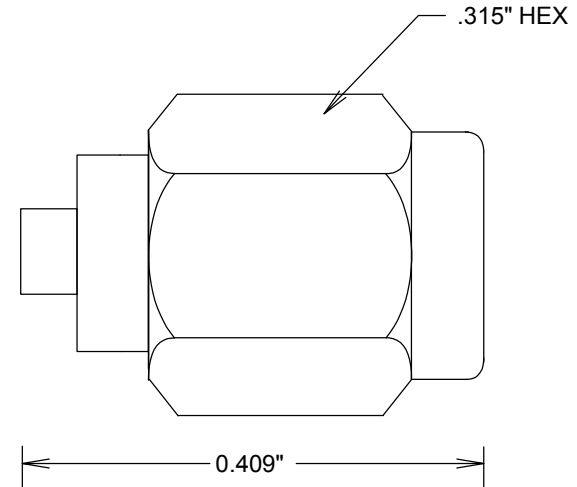

**FAIRVIEW MICROWAVE INC.**

ALLEN, TX 75013 WWW.FAIRVIEWMICROWAVE.COM

TITLE

**2.92mm M .085 SEMI-RIGID**

SIZE	CAGE CODE	DWG NO	REV
<b>A</b>	<b>3FKR5</b>	<b>SMC292-085M</b>	--

SCALE

SHEET