

**Feed-Thru Load 2 Watts To 1,000 MHz Tri-Metal Plated Brass BNC Male**

RF feed-thru termination (also called RF feed-thru load) ST0150 from Fairview Microwave operates from DC to 1,000 MHz and handles up to 2 Watts (CW). ST0150 BNC feed-thru load termination offers 1.3:1 max VSWR. This feed-thru BNC male to BNC female load is designed to be used with oscilloscopes and other test equipment to match to the 50 Ohm device under test (DUT).

RF terminations / loads are critical passive components in many RF, microwave and millimeter wave systems where signal reflection from unused ports can reduce the signal integrity and can potentially damage the device. By terminating an unused port with a matched load (dummy load), the incident energy will be absorbed with minimal reflection. These radio frequency termination components are commonly used to terminate devices such as couplers, circulators, and switches. Loads / terminations are also widely used in measurement systems to ensure accurate results. Fairview offers a large selection of in-stock RF, microwave and millimeter wave terminations to fit your needs.

**Electrical Specifications**

Description	Min	Typ	Max	Units
Frequency Range	DC		1,000	MHz
Impedance		50		Ohms
VSWR			1.3:1	
Input Power (CW)			2	Watts

**Performance by Frequency**

Description	F1	F2	F3	F4	F5	Units
Frequency Range	DC - 0.1	0.1 - 0.5	0.5 - 1			GHz
VSWR, Max	1.1:1	1.25:1	1.3:1			

Electrical Specification Notes:  
 Values at +25°C, sea level.

**Mechanical Specifications**

<b>Size</b>	
Length	1.77 in [44.96 mm]
Width	0.57 in [14.48 mm]
Weight	0.049 lbs [22.23 g]

**Configuration**

Connector 1	BNC Male
Connector 2	BNC Female



**Features:**

- DC to 1,000 MHz Frequency Range
- VSWR 1.3:1 Max
- Max Power 2 Watts (CW)
- BNC Male to Female Coaxial Interface

**Applications:**

- Wireless
- SATCOM
- Radar Systems
- Test and Measurement
- Commercial Communication
- Military Communication

Fairview Microwave  
 1130 Junction Dr. #100  
 Allen, TX 75013  
 Tel: 1-800-715-4396 / (972) 649-6678  
 Fax: (972) 649-6689  
[www.fairviewmicrowave.com](http://www.fairviewmicrowave.com)  
[sales@fairviewmicrowave.com](mailto:sales@fairviewmicrowave.com)

**Material Specifications**

Description	Material	Plating
Connector 1 Contact	Phosphor Bronze	Gold over Nickel 20 µin minimum
Connector 2 Contact	Phosphor Bronze	Gold over Nickel 20 µin minimum
Insulation	PTFE	
Body	Brass	Tri-Metal 100 µin minimum
Coupling Nut	Brass	Tri-Metal 100 µ-in.
Housing	Brass	Tri-Metal 100 µin minimum

**Compliance Certifications** (see [product page](#) for current document)

**Plotted and Other Data**

Notes:

**Typical Performance Data**

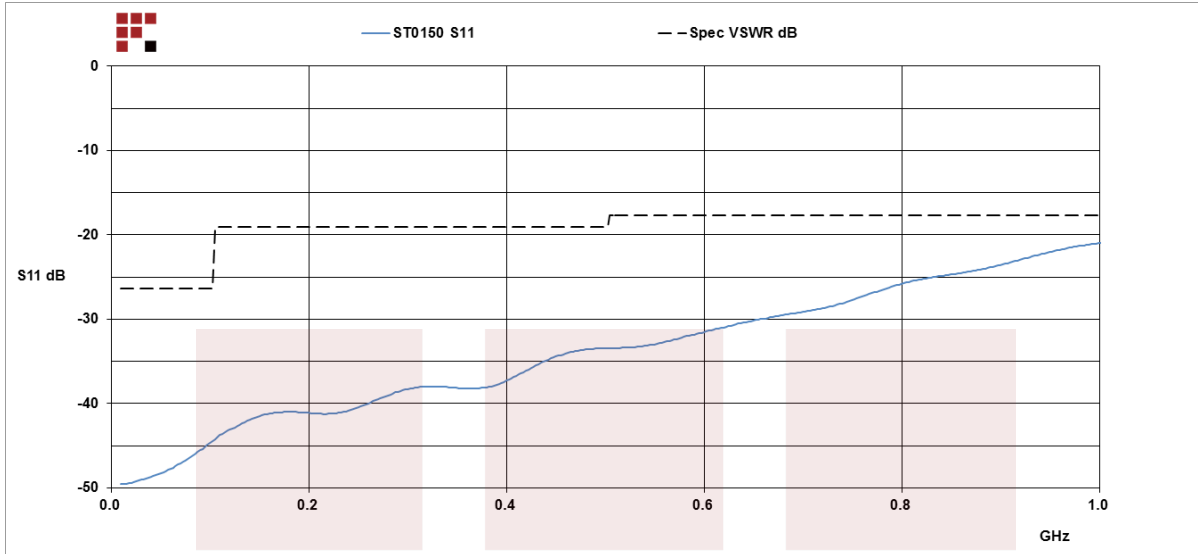

Feed-Thru Load 2 Watts To 1,000 MHz Tri-Metal Plated Brass BNC Male from Fairview Microwave is in-stock and available to ship same-day. All of our RF/microwave products are available off-the-shelf from our ISO 9001:2008 certified facilities in Allen, Texas. Fairview Microwave is RF on-demand.

For additional information on this product, please click the following link: [Feed-Thru Load 2 Watts To 1,000 MHz Tri-Metal Plated Brass BNC Male ST0150](#)

URL: <https://www.fairviewmicrowave.com/feed-thru-load-2-watts-1000-mhz-bnc-male-st0150-p.aspx>

The information contained in this document is accurate to the best of our knowledge and representative of the part described herein. It may be necessary to make modifications to the part and/or the documentation of the part, in order to implement improvements. Fairview Microwave reserves the right to make such changes as required. Unless otherwise stated, all specifications are nominal. Fairview Microwave does not make any representation or warranty regarding the suitability of the part described herein for any particular purpose, and Fairview Microwave does not assume any liability arising out of the use of any part or documentation.

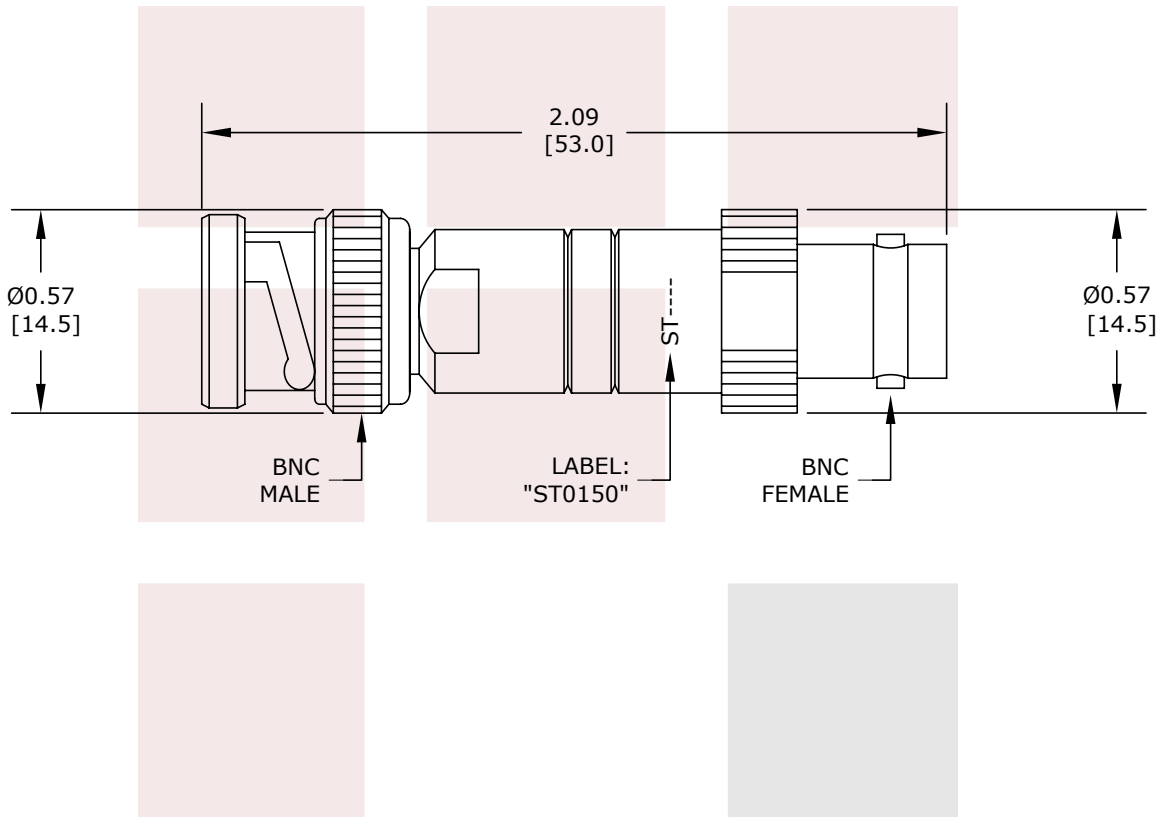

STANDARD TOLERANCES	
.X	±0.2
.XX	±0.1
.XXX	±0.05

\*STANDARD TOLERANCES APPLY ONLY TO DIMENSIONS IN INCHES

<b>FAIRVIEW MICROWAVE INC.</b> ALLEN, TX 75013 WWW.FAIRVIEWMICROWAVE.COM		NOTES: 1. UNLESS OTHERWISE SPECIFIED ALL DIMENSIONS ARE NOMINAL. 2. ALL SPECIFICATIONS ARE SUBJECT TO CHANGE WITHOUT NOTICE AT ANY TIME. 3. DIMENSIONS ARE IN INCHES [mm].			
TITLE Feed-Thru Load 2 Watts To 1,000 MHz Tri-Metal Plated Brass BNC Male		DWG NO <b>ST0150</b>		CAGE CODE <b>3FKR5</b>	
CAD FILE	070716	SHEET	SCALE	N/A	SIZE A 3045