

Miter RA 2.92mm Female to 2.92mm Female Adapter with Passivated Stainless Steel Body

Miter RA 2.92mm female to 2.92mm female adapter part number FMAD1219 from Fairview Microwave is in-stock and ships same day. This Fairview 2.92mm to 2.92mm adapter has a female to female gender configuration and is built of durable stainless steel. FMAD1219 2.92mm female to 2.92mm female adapter operates to 40 GHz. The Fairview Microwave RF adapter provides excellent VSWR of 1.25:1 maximum. The 2.92mm connector mates mechanically with commercially available SMA and 3.5mm connectors. This miter right angle 2.92mm adapter allows for easier connections in tight spaces.

RF adapters can be used to enable connections between two connector types that would otherwise not mate. Certain RF adapter configurations can also be used to protect connectors on expensive equipment where the number of connect and disconnect cycles is high. An RF, microwave, or millimeter wave adapter is connected to the equipment and the commonly changed connection is made with the adapter which can be easily replaced when it wears out after high usage; such adapters are referred to as connector savers. Fairview Microwave also offers bulkhead, panel mount, hermetically sealed, reverse polarity, and isolated ground adapter varieties to serve all of your RF, microwave and millimeter wave needs.

Electrical Specifications

Description	Min	Typ	Max	Units
Frequency Range	DC		40	GHz
VSWR			1.25:1	

Mechanical Specifications

Size	
Length	6.2 in [158.0 mm]
Height	5.9 in [149.86 mm]

Description	Connector 1	Connector 2
Type	2.92mm Female	2.92mm Female
Polarity	Standard	Standard

Material Specifications

Description	Connector 1	Connector 2
Type	2.92mm Female	2.92mm Female
Contact Material	Beryllium Copper	Beryllium Copper
Contact Plating	Gold over Nickel	Gold over Nickel
Contact Plating Spec.	4 μin. Minimum	4 μin. Minimum
Insulation Material	Oxide-Noryl	Oxide-Noryl
Outer Contact Material	Passivated Stainless Steel	Passivated Stainless Steel
Body Material	Passivated Stainless Steel	Passivated Stainless Steel

Compliance Certifications (see [product page](#) for current document)

Plotted and Other Data

Notes:



Configuration:

- 2.92mm Female Connector 1
- 2.92mm Female Connector 2
- 50 Ohm
- Miter Right Angle Body Geometry

Features:

- VSWR of 1.25:1 max up to 40 GHz
- 4 μin. Minimum contact plating
- Gold over Nickel Plated Beryllium Copper Contact

Applications:

- General Purpose Test

Fairview Microwave
 301 Leora Ln., Suite 100
 Lewisville, TX 75056
 Tel: 1-800-715-4396 / (972) 649-6678
 Fax: (972) 649-6689
www.fairviewmicrowave.com
sales@fairviewmicrowave.com

Miter RA 2.92mm Female to 2.92mm Female Adapter with Passivated Stainless Steel Body from Fairview Microwave is in-stock and available to ship same-day. All of our RF/microwave products are available off-the-shelf from our ISO 9001:2008 certified facilities in Lewisville, Texas. Fairview Microwave is RF on-demand.

For additional information on this product, please click the following link: [Miter RA 2.92mm Female to 2.92mm Female Adapter with Passivated Stainless Steel Body FMAD1219](#)

URL: <https://www.fairviewmicrowave.com/ra-2.92mm-female-2.92mm-female-adapter-fmad1219-p.aspx>

The information contained in this document is accurate to the best of our knowledge and representative of the part described herein. It may be necessary to make modifications to the part and/or the documentation of the part, in order to implement improvements. Fairview Microwave reserves the right to make such changes as required. Unless otherwise stated, all specifications are nominal. Fairview Microwave does not make any representation or warranty regarding the suitability of the part described herein for any particular purpose, and Fairview Microwave does not assume any liability arising out of the use of any part or documentation.



REVISIONS			
REV.	DESCRIPTION	DATE	APPROVED
A	INITIAL RELEASE	12/13/19	S.ELLIS

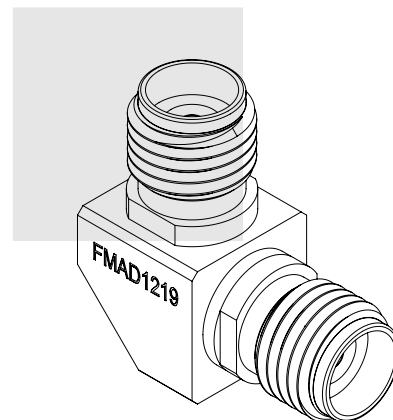
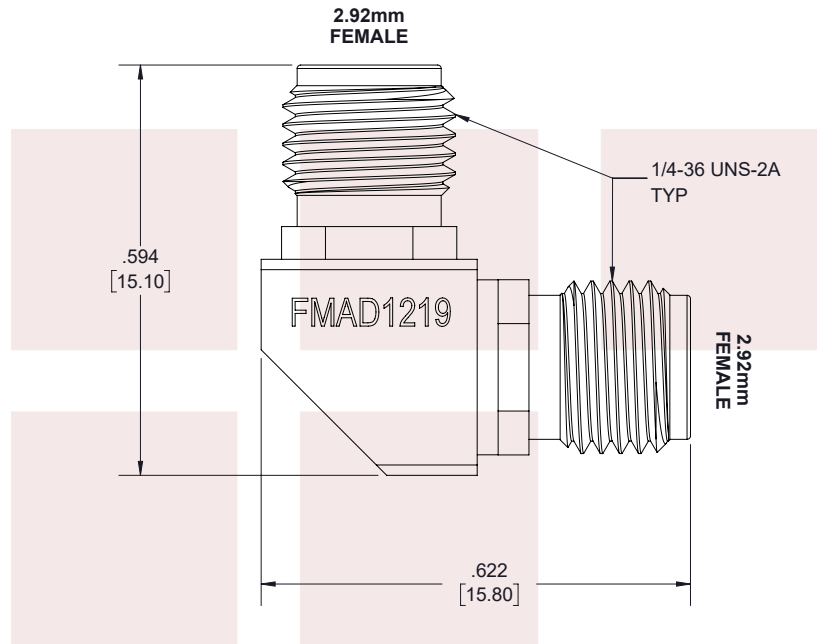

THESE COMMODITIES, TECHNOLOGY OR SOFTWARE WERE EXPORTED FROM THE UNITED STATES IN ACCORDANCE WITH THE EXPORT ADMINISTRATION REGULATIONS. DIVERSION CONTRARY TO U.S. LAW PROHIBITED.

TITLE
Miter RA 2.92mm Female to 2.92mm Female Adapter with Passivated Stainless Steel Body

UNLESS OTHERWISE SPECIFIED LEADING DIMENSIONS ARE INCHES
DIMENSIONS IN [] ARE MILLIMETERS

TOLERANCES:		CABLE LENGTH (L) TOLERANCES:	
.X = ±.2 [5.08]	FRACTIONS ± 1/32	L ≤ 12 [305] = +1 [25] / -0	
.XX = ±.02 [.51]		12 [305] < L ≤ 60 [1524] = +2 [51] / -0	
.XXX = ±.005 [.13]	ANGLES ± 1°	60 [1524] < L ≤ 120 [3048] = +4 [102] / -0	
		120 [3048] < L ≤ 300 [7620] = +6 [152] / -0	
		300 [7620] < L = +5%L / -0	

THIRD-ANGLE PROJECTION



THE INFORMATION AND DESIGN IN THIS DOCUMENT IS THE PROPERTY OF FAIRVIEW MICROWAVE CORPORATION. ALL RIGHTS RESERVED.

SHEET	1	OF	1
-------	---	----	---

SCALE N/A

ALL DIMENSIONS SHOWN ARE FOR REFERENCE ONLY.

SIZE A	CAGE CODE 3FKR5	DRAWN BY K.DANG	ITEM NO. FMAD1219	REV A
-----------	--------------------	--------------------	----------------------	----------

T-Rev.D