

## High Power LDMOS Amplifier at 4 Watt Psat Operating from 1 MHz to 1 GHz with 39 dBm IP3, SMA Input, SMA Output and 36 dB Gain

The FMAM5030 is a high gain Class A/AB coaxial Linear Power Amplifier operating in the 1 to 1000 MHz frequency range. The highly linear design supports a variety of input signal formats which includes CW, AM, FM, PM, and Pulse. The amplifier offers a Wide Dynamic Range with 4 Watts typical (2 Watt minimum) saturated power, 36 dB typical small signal gain,  $\pm 1.5$  dB gain flatness maximum, and a high Output IP3 of +39 dBm typical. Additional performance features include -28 dBc harmonics at 2 watts, <-60 dBc spurious at 2 watts and a max RF input power of +3 dBm. The amplifier requires typically a +28V DC power supply, is unconditionally stable, and operates over the temperature range of 0°C and +50°C. The connectorized SMA module also supports an open collector shutdown pin that's left open for normal operation and shorted to ground to shutdown the amplifier. The rugged package design meets a series of environmental conditions which includes Humidity, Altitude, Shock, and Vibration. A heat sink is required for adequate cooling.

### Electrical Specifications

(TA = +25°C, DC Voltage = 28Volts , DC Current = 1.2A)

Description	Min	Typ	Max	Unit
Frequency Range	1		1,000	MHz
Small Signal Gain	36			dB
Gain Flatness			$\pm 1.5$	dB
Input Power (CW)			+3	dBm
Psat		+36		dBm
P1dB	+33			dBm
Output 3rd Order Intercept Point		+39		dBm
Harmonics @2 Watts		-20		dBc
Spurious @2 Watts		-60		dBc
Impedance (Input)		50		Ohms
Impedance (Output)		50		Ohms
Input VSWR			2:1	
TTL Control	"1": Off, "0": On (Blanking), Enable: 0V, Disable: 5V			
Operating DC Voltage		28		Volts
Operating DC Current			1.2	A
Shutdown On/Off Speed			350	ms
Operating Temperature Range	0		+50	°C

### Mechanical Specifications

<b>Size</b>	
Length	6 in [152.4 mm]
Width	3 in [76.2 mm]
Height	1.1 in [27.94 mm]
Weight	0.9635 lbs [437.04 g]
Input Connector	SMA Female
Output Connector	SMA Female
Cooling	ADEQUATE HEATSINK REQUIRED

### Environmental Specifications



### Features:

- 1 MHz to 1000 MHz Frequency Range
- Psat 4 Watts typ
- Small Signal Gain: 36 dB min
- Gain Flatness  $\pm 1.5$  dB max
- Class A/AB
- IP3 39 dBm typ
- 50 Ohms Input and Output Matched
- Unconditionally Stable
- Regulated Supply
- RF Input Signal Format CW/AM/FM/PM/Pulse
- SMA Female RF Connectors
- Shutdown Feature

### Applications:

- Military Radio
- Communication Systems
- High Gain Driver Power Amplifier
- High Gain Output Power Amplifier

Fairview Microwave  
301 Leora Ln., Suite 100  
Lewisville, TX 75056  
Tel: 1-800-715-4396 / (972) 649-6678  
Fax: (972) 649-6689  
[www.fairviewmicrowave.com](http://www.fairviewmicrowave.com)  
[sales@fairviewmicrowave.com](mailto:sales@fairviewmicrowave.com)

**Temperature**

Operating Range	0 to +50 deg C
Humidity	95
Shock	Normal Truck Transport
Vibration	Normal Truck Transport
Altitude	10000

**Compliance Certifications** (see [product page](#) for current document)

**Plotted and Other Data**

Notes:

- Values at 25 °C, sea level
- ESD Sensitive Material, Transport material in Approved ESD bags. Handle only in approved ESD Workstation.
- Heat Sink Required for Proper Operation, Unit is cooled by conduction to heat sink.

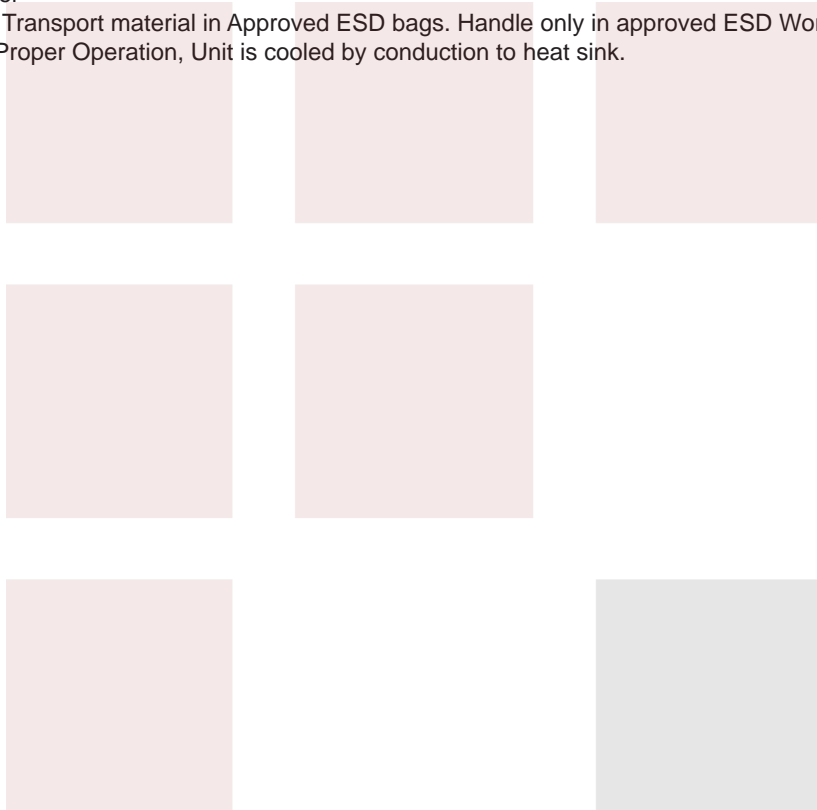

## Amplifier Power-up Precautions

- 1.) Confirm that proper ESD precautions and controls are always in place before handling any Amplifier module.
- 2.) Confirm adequate thermal management is in place to effectively dissipate heat away from the Amplifier package. The Amplifier operational baseplate temperature must be within the operational temperature range stated in the Amplifier datasheet. Depending on the design and thermal requirements, using a heatsink with cooling fan is always recommended for safe reliable operation. A heat sink without a cooling fan may also be used. Damage caused from overheating will void the warranty.
- 3.) Confirm adequate system grounding is established. The DC power supply and Amplifier must have a common ground in order to operate properly.
- 4.) Power Amplifiers may require additional DC Current when initially powered-up. Depending on the design, the input current draw could range from an additional 10% to 100% above the maximum rated DC current of the Amplifier. This varies based on product part number.
- 5.) Confirm the DC power supply, if limited, is set to allow for additional start-up current that's rated for the Power Amplifier.
- 6.) Confirm the system is designed and calibrated for 50 ohms. Any impedance mismatch may cause performance issues.
- 7.) Perform a CALIBRATION (if required) with the loads before connecting the Amplifier to the Network Analyzer to ensure proper performance.
- 8.) Use a fixed attenuator between the signal source and input port of the Amplifier to optimize the input VSWR match.
- 9.) Confirm the input power level at the input port of the amplifier does not exceed the maximum rated limit for input power (as stated in the Amplifier datasheet).  
 $P_{in}$  for Small Signal Gain = P1dB-SSG-10 dB  
 $P_{in}$  for P1dB = P1dB-SSG+1 dB
- 10.) Confirm the Network Analyzer is always connected to the Amplifier first before DC power is applied to the Amplifier.
- 11.) As long as the input and output ports of the amplifier are connected to a 50ohm load and RF signal power is applied, the Amplifier can be powered up with DC voltage.
- 12.) Confirm the Amplifier output load is matched for a 50 Ohm impedance and will not exceed the maximum rated VSWR or Return Loss limit for the Amplifier. Exceeding the maximum rated VSWR or Return Loss limit will result in reflected signal power that could damage the Amplifier and void the warranty.
- 13.) **Power Amplifier connected to an Antenna for signal transmission** - It's strongly recommended to use a high power fixed attenuator pad or an Isolator between the output port of the Amplifier and input port to the antenna. Any reflected signal power due to impedance mismatch will likely damage the Amplifier and void the warranty.
- 14.) The attenuator or isolator used at the output port of the Amplifier must be rated to handle the output power level and operational frequency band of the amplifier.

**SHUTDOWN PIN FEATURE:** The open collector is not designed to have any voltage applied to it. It can actually damage the amplifier if voltage is applied. The pin leads directly to the gate voltage that turns on the internal transistors. There's a diode in series to protect it from input voltage but if the voltage is too high, it can cause damage.

For normal operation, the shutdown pin is left open. If the amplifier module needs to be shutdown, the pin is shorted to ground. Some external control options could involve using a toggle switch and turn off the module. Another external control option could involve using a Darlington transistor and control the transistor with TTL logic. In this case, the transistor would remain open for normal operation and control the transistor to close to ground for a shutdown.

**Typical Performance Data**

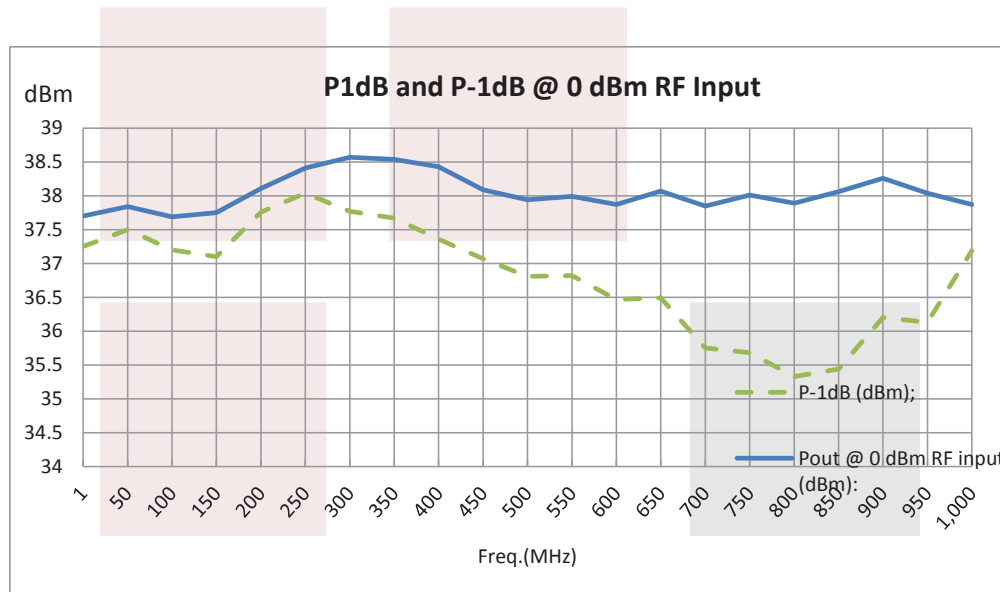
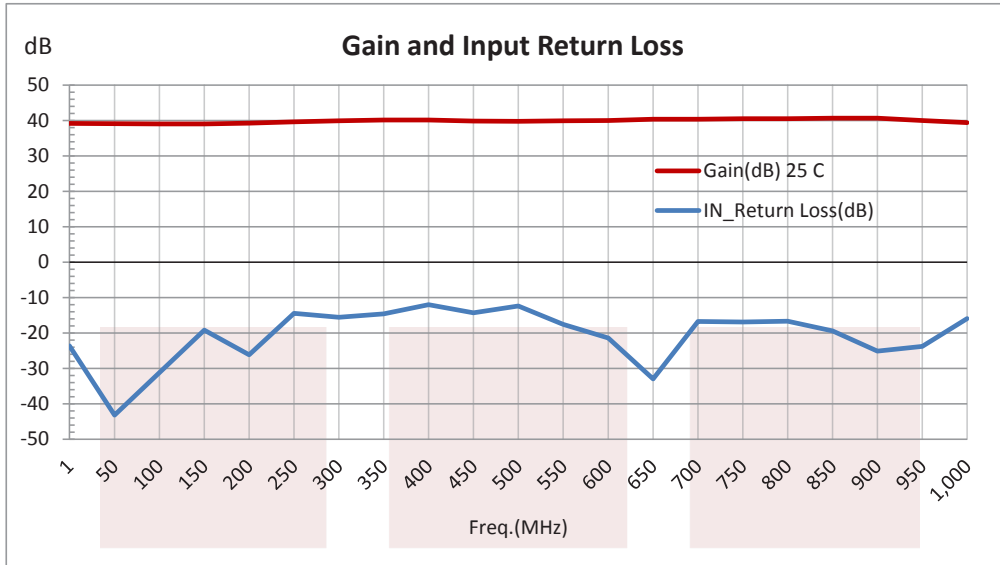

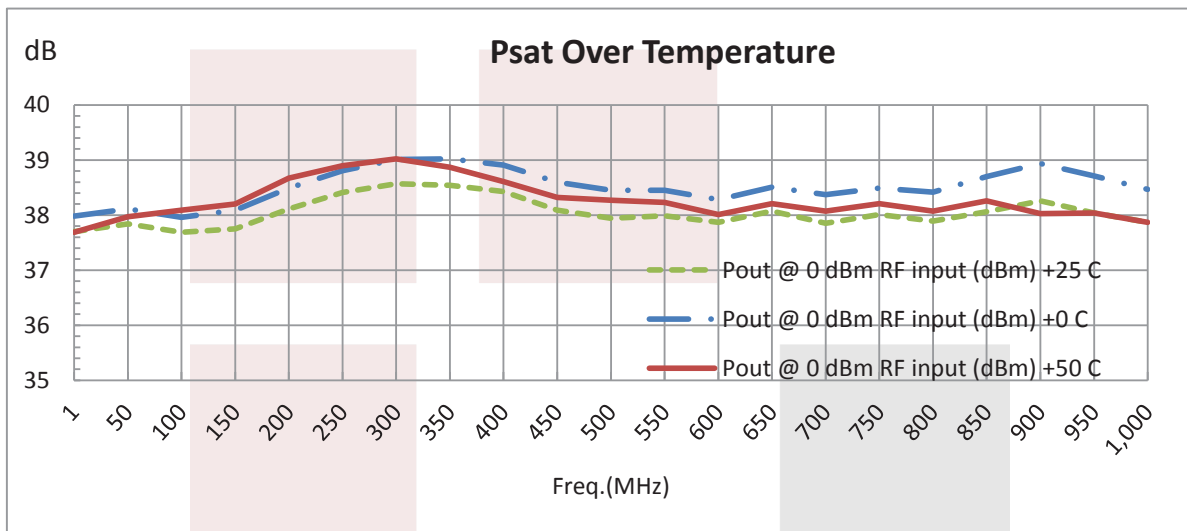
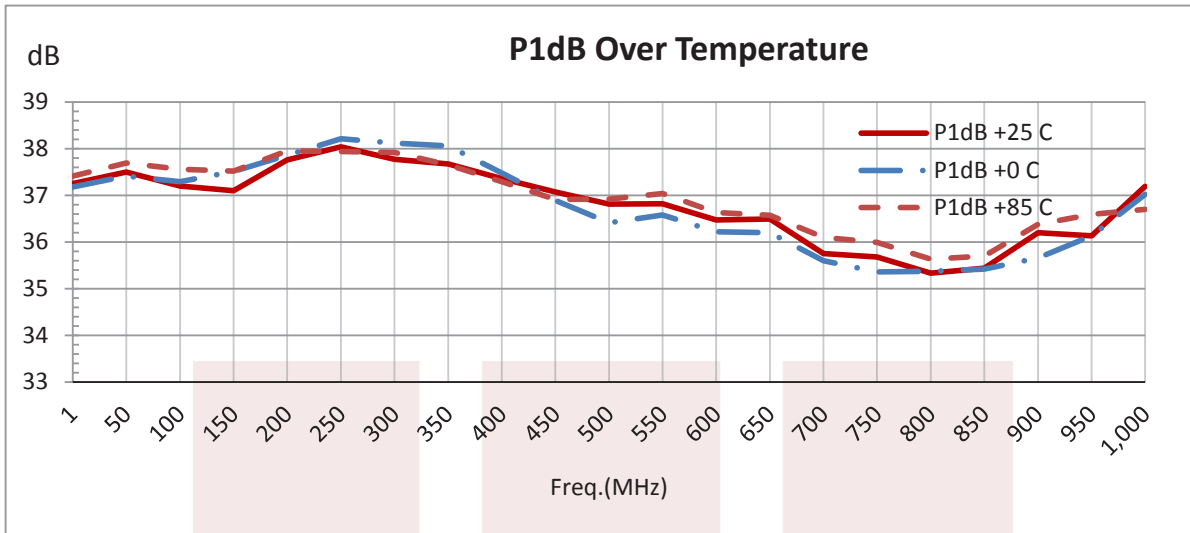

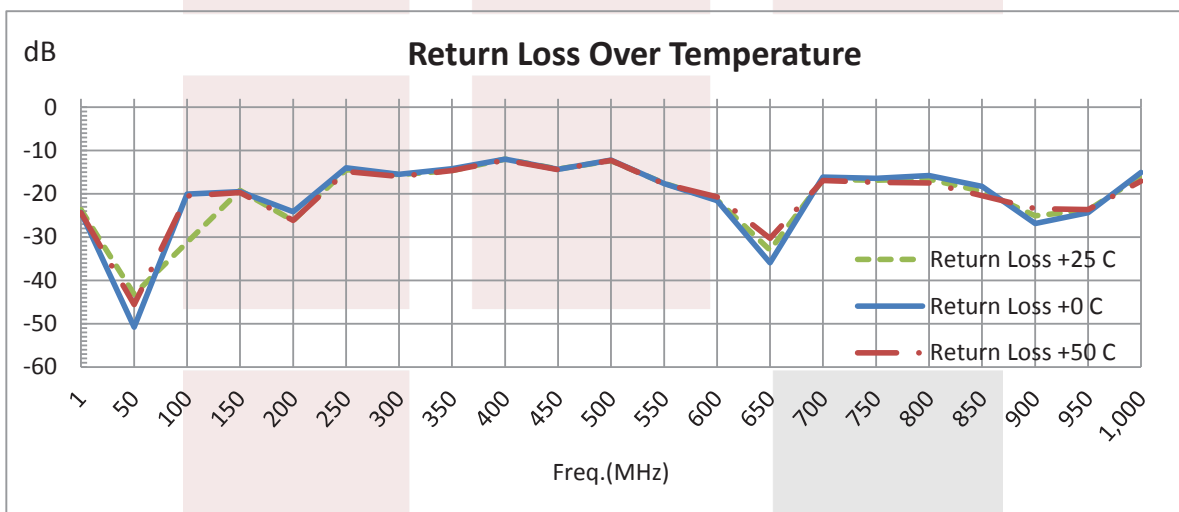
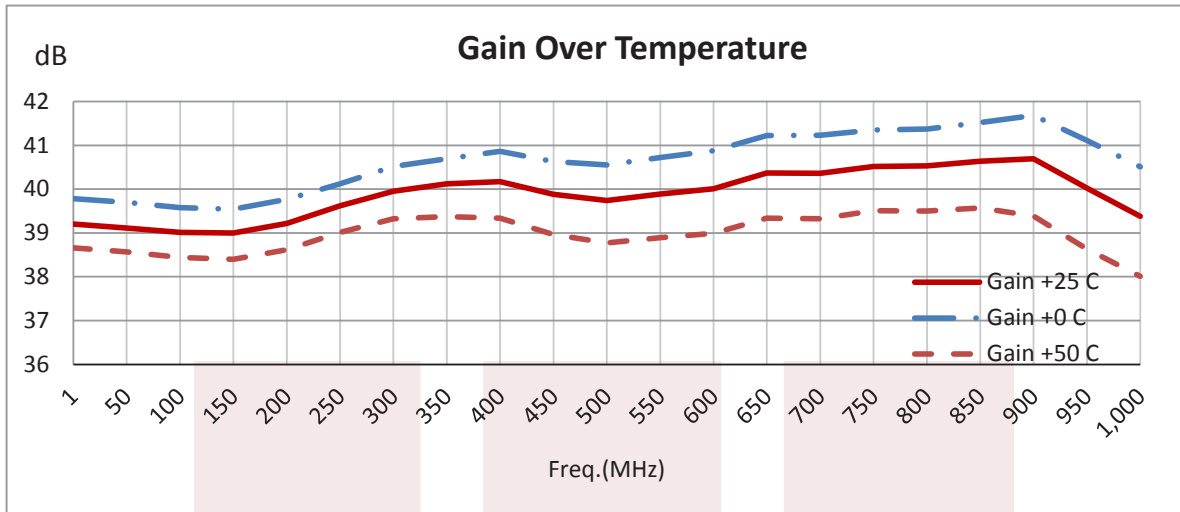

High Power LDMOS Amplifier at 4 Watt Psat Operating from 1 MHz to 1 GHz with 39 dBm IP3, SMA Input, SMA Output and 36 dB Gain from Fairview Microwave is in-stock and available to ship same-day. All of our RF/microwave products are available off-the-shelf from our ISO 9001:2008 certified facilities in Allen, Texas. Fairview Microwave is RF on-demand.

For additional information on this product, please click the following link: [High Power LDMOS Amplifier at 4 Watt Psat Operating from 1 MHz to 1 GHz with 39 dBm IP3, SMA Input, SMA Output and 36 dB Gain FMAM5030](https://www.fairviewmicrowave.com/high-power-amplifier-4watt-36db-fmam5030-p.aspx)

URL: <https://www.fairviewmicrowave.com/high-power-amplifier-4watt-36db-fmam5030-p.aspx>

The information contained in this document is accurate to the best of our knowledge and representative of the part described herein. It may be necessary to make modifications to the part and/or the documentation of the part, in order to implement improvements. Fairview Microwave reserves the right to make such changes as required. Unless otherwise stated, all specifications are nominal. Fairview Microwave does not make any representation or warranty regarding the suitability of the part described herein for any particular purpose, and Fairview Microwave does not assume any liability arising out of the use of any part or documentation.

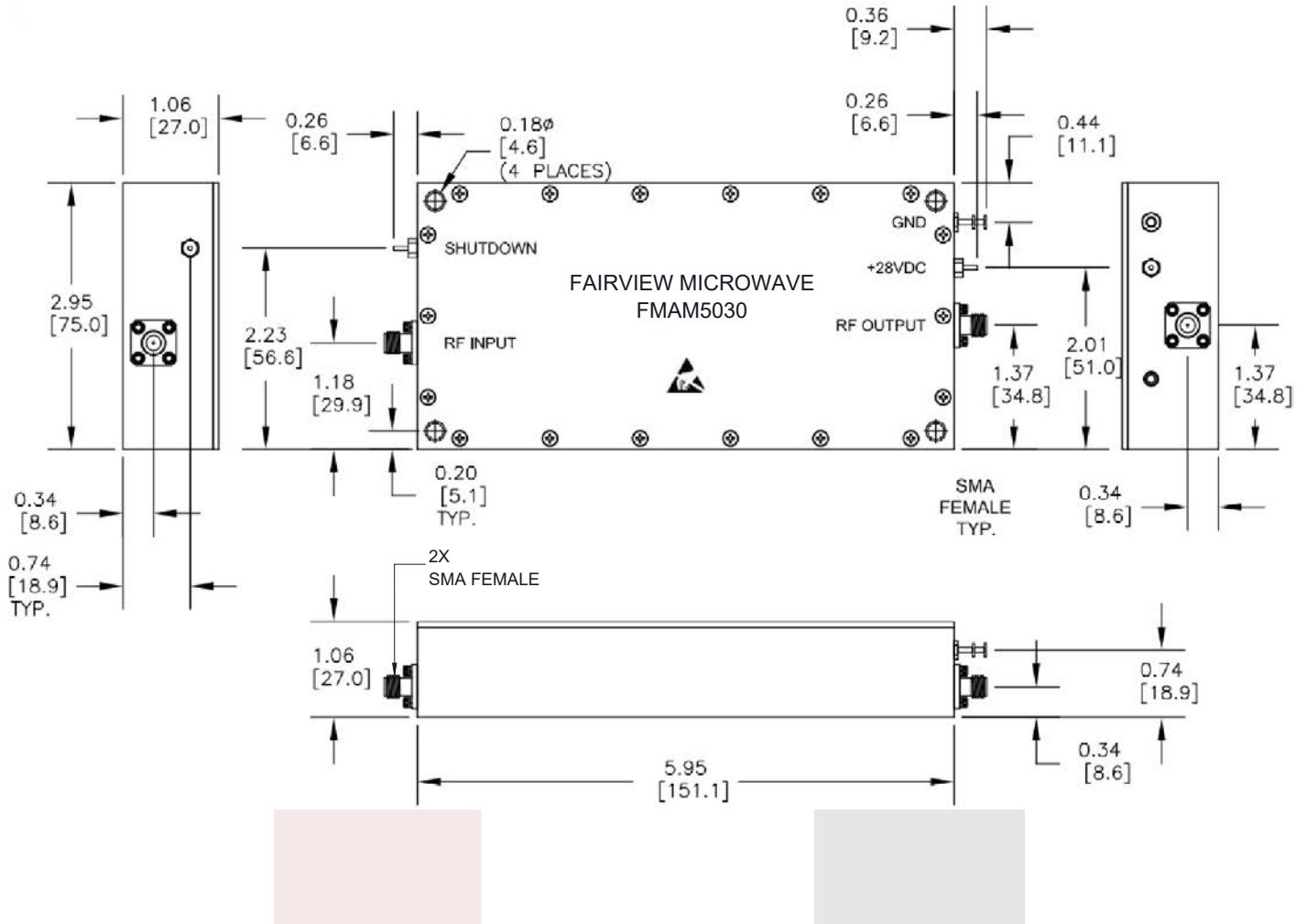

STANDARD TOLERANCES	
.X	±0.2
.XX	±0.01
.XXX	±0.005

\*STANDARD TOLERANCES APPLY ONLY TO DIMENSIONS IN INCHES

**NOTES:**

- HEAT SINK REQUIRED FOR PROPER OPERATION, UNIT IS COOLED BY CONDUCTING TO HEAT SINK.
- FOR SHUTDOWN PIN USE A MANUAL TOGGLE SWITCH WITH AN OPEN ON ONE END AND SHORT ON THE OTHER END. ONCE THE PIN IS SHORTED OUT, THE AMPLIFIER WILL SHUT DOWN.
- TTL METHOD: USE A DARLINGTON TRANSISTOR (DARLINGTON PAIR) THAT IS CONNECTED TO A TTL OF YOUR CHOICE WITH AN OPEN AND SHORT PORT. WHEN TTL GOES HIGH (5V), THE UNIT WILL SHUT DOWN.

<b>FAIRVIEW MICROWAVE INC.</b> ALLEN, TX 75013 WWW.FAIRVIEWMICROWAVE.COM		NOTES: 1. UNLESS OTHERWISE SPECIFIED ALL DIMENSIONS ARE NOMINAL. 2. ALL SPECIFICATIONS ARE SUBJECT TO CHANGE WITHOUT NOTICE AT ANY TIME. 3. DIMENSIONS ARE IN INCHES [mm].		
TITLE	DWG NO	CAGE CODE		
High Power LDMOS Amplifier at 4 Watt Psat Operating from 1 MHz to 1 GHz with 39 dBm IP3, SMA Input, SMA Output and 36 dB Gain	FMAM5030	3FKR5		
	CAD FILE 021318	SHEET 1 OF 1	SCALE N/A	
		SIZE A	7361	