

REVISIONS			
REV.	DESCRIPTION	DATE	APPROVED
B	ECN: 11417	10/11/2021	DGUST

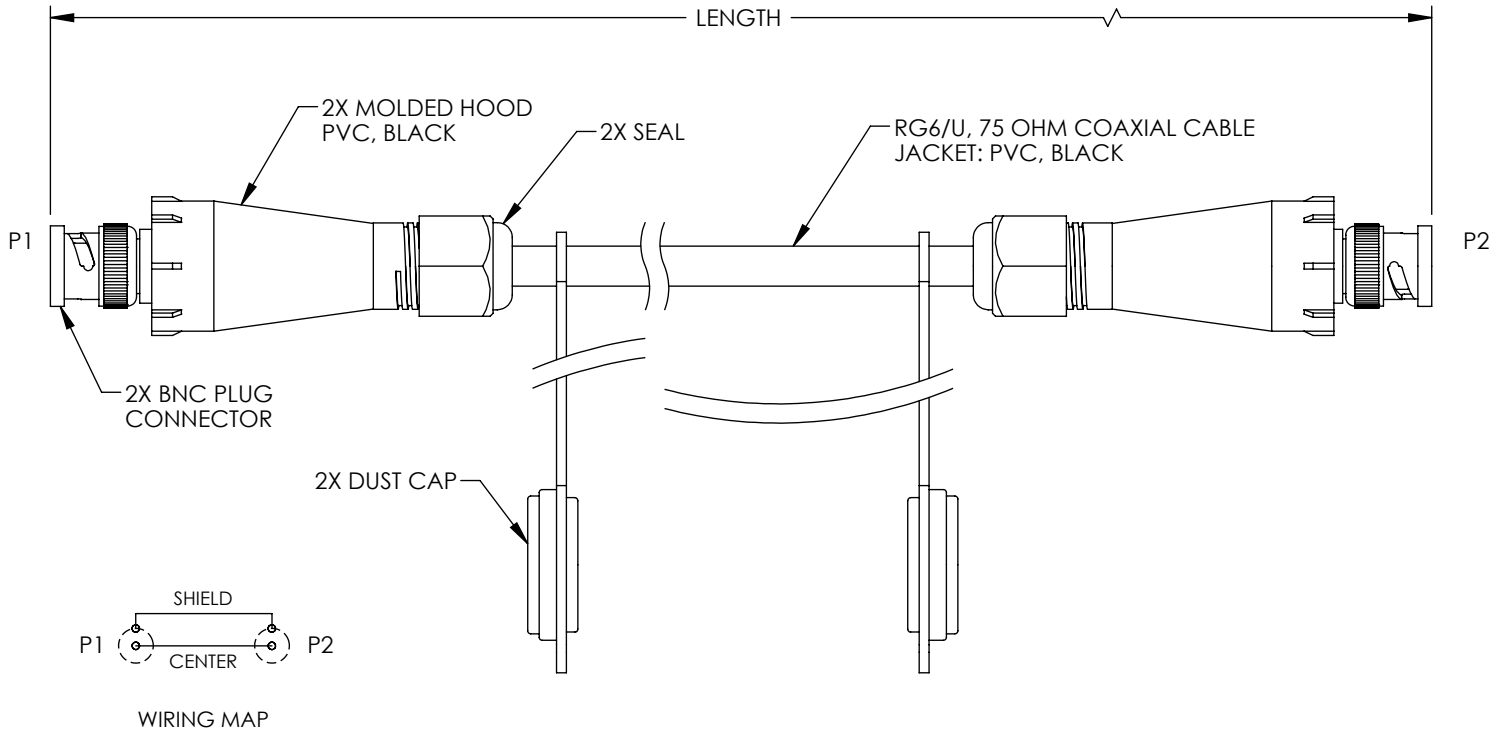

MODEL NUMBER	LENGTH (METERS)	TOLERANCE (mm)
FMCA2383-100CM	1.0	+/- 50.0
FMCA2383-200CM	2.0	+/- 50.0
FMCA2383-500CM	5.0	+152.0 / -51.0
FMCA2383-1000CM	10.0	+152.0 / -51.0



NOTES:

1. CABLE ASSEMBLY SHALL BE TESTED FOR CONTINUITY.
2. IP RATING: IP 68, WHEN MATED
3. CABLE ASSEMBLY SHALL BE INDIVIDUALLY PACKAGED.

THESE COMMODITIES, TECHNOLOGY OR SOFTWARE WERE EXPORTED FROM THE UNITED STATES IN ACCORDANCE WITH THE EXPORT ADMINISTRATION REGULATIONS. DIVERSION CONTRARY TO U.S. LAW PROHIBITED.



TITLE

UNLESS OTHERWISE SPECIFIED LEADING DIMENSIONS ARE INCHES
DIMENSIONS IN [] ARE MILLIMETERS

TOLERANCES: CABLE LENGTH (L) TOLERANCES:

.X = ±.2 [5.08] FRACTIONS ± 1/32
.XX = ±.02 [.51] ANGLES ± 1°
XXX = ±.005 [.13]

L ≤ 12 [305] = +1 [25] / -0
12 [305] < L ≤ 60 [1524] = +2 [51] / -0
60 [1524] < L ≤ 120 [3048] = +4 [102] / -0
120 [3048] < L ≤ 300 [7620] = +6 [152] / -0
300 [7620] < L = +5%L / -0

THIRD-ANGLE PROJECTION

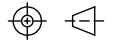

THE INFORMATION AND DESIGN IN THIS DOCUMENT IS THE PROPERTY OF FAIRVIEW MICROWAVE CORPORATION. ALL RIGHTS RESERVED.

SHEET 1 OF 1

ALL DIMENSIONS SHOWN ARE FOR REFERENCE ONLY.

SCALE N/A

SIZE A	CAGE CODE 3FKR5	DRAWN BY DMAY	ITEM NO. FMCA2383	REV B
--------	-----------------	---------------	-------------------	-------