

SSMA Female Connector Crimp/Solder Attachment For RG178, RG196

SSMA female connector with crimp/solder attachment for RG178 and RG196, part number FMCN1856, from Fairview Microwave is in-stock and ships same day.

Fairview's SSMA female connector FMCN1856 datasheet specifications and outline drawing are shown in this PDF below. Our extensive offering of RF, microwave and millimeter wave connectors allows designers to configure and customize their signal connections however they like. From providing an I/O for a board design to creating a custom cable assembly configuration, Fairview Microwave has a connector solution to meet your needs. Fairview Microwave also has the expertise to build your custom cable assemblies for you and ship them same-day.

Mechanical Specifications

Size

Length	0.83 in [21.08 mm]
Width/Dia.	0.25 in [6.35 mm]
Height	0.5 in [12.7 mm]
Weight	0.006 lbs [2.72 g]

Material Specifications

Description	Material	Plating
Contact		Gold MIL-G-45204
Insulation	Teflon	
Body	Brass	Nickel

Environmental Specifications Temperature

Operating Range	-65 to +165 deg C
-----------------	-------------------

Compliance Certifications (see [product page](#) for current document)

Plotted and Other Data

Notes:



Configuration:

- SSMA Female Connector
- MIL-C-39012
- 50 Ohms
- Straight Body Geometry
- RG178, RG196 Interface Type
- Crimp/Solder Attachment

Features:

- Gold Plated Contact
- Contact plating according to MIL-G-45204

Applications:

- General Purpose Test
- Custom Cable Assemblies

Fairview Microwave
301 Leora Ln., Suite 100
Lewisville, TX 75056
Tel: 1-800-715-4396 / (972) 649-6678
Fax: (972) 649-6689
www.fairviewmicrowave.com
sales@fairviewmicrowave.com

SSMA Female Connector Crimp/Solder Attachment For RG178, RG196 from Fairview Microwave is in-stock and available to ship same-day. All of our RF/microwave products are available off-the-shelf from our ISO 9001:2008 certified facilities in Lewisville, Texas. Fairview Microwave is RF on-demand.

For additional information on this product, please click the following link: [SSMA Female Connector Crimp/Solder Attachment For RG178, RG196 FMCN1856](#)

URL: <https://www.fairviewmicrowave.com/ssma-female-rg178-rg196-connector-fmcn1856-p.aspx>

The information contained in this document is accurate to the best of our knowledge and representative of the part described herein. It may be necessary to make modifications to the part and/or the documentation of the part, in order to implement improvements. Fairview Microwave reserves the right to make such changes as required. Unless otherwise stated, all specifications are nominal. Fairview Microwave does not make any representation or warranty regarding the suitability of the part described herein for any particular purpose, and Fairview Microwave does not assume any liability arising out of the use of any part or documentation.



REVISIONS			
REV.	DESCRIPTION	DATE	APPROVED
A	INITIAL RELEASE	2/10/2022	A.GANWANI

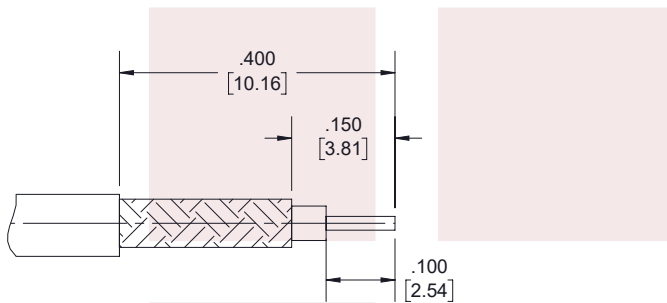
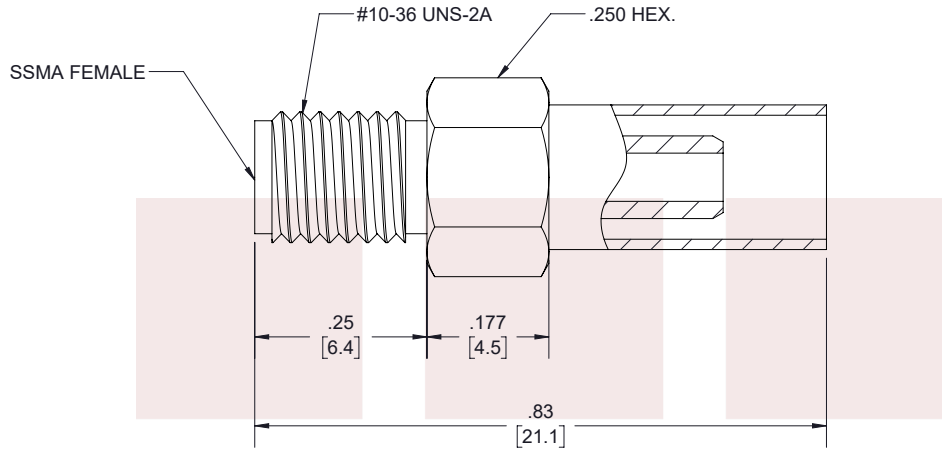

STRIPPING DIMENSIONS

CRIMP SIZE REQUIRED

CONTACT: SOLDER.
FERRULE: .100" [2.54] HEX CRIMP TOOL.

THESE COMMODITIES, TECHNOLOGY OR SOFTWARE WERE EXPORTED FROM THE UNITED STATES IN ACCORDANCE WITH THE EXPORT ADMINISTRATION REGULATIONS. DIVERSION CONTRARY TO U.S. LAW PROHIBITED.

TITLE

SSMA Female Connector Crimp/Solder Attachment For RG178, RG196

UNLESS OTHERWISE SPECIFIED LEADING DIMENSIONS ARE INCHES
DIMENSIONS IN [] ARE MILLIMETERS

TOLERANCES: CABLE LENGTH (L) TOLERANCES:

.X = ±.2 [5.08]	FRACTIONS ± 1/32	L ≤ 12 [305] = +1 [25] / -0
.XX = ±.02 [.51]	ANGLES ± 1°	12 [305] < L ≤ 60 [1524] = +2 [51] / -0
.XXX = ±.005 [.13]		60 [1524] < L ≤ 120 [3048] = +4 [102] / -0
		120 [3048] < L ≤ 300 [7620] = +6 [152] / -0
		300 [7620] < L = +5%L / -0

THIRD-ANGLE PROJECTION

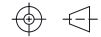

THE INFORMATION AND DESIGN IN THIS DOCUMENT IS THE PROPERTY OF FAIRVIEW MICROWAVE CORPORATION. ALL RIGHTS RESERVED.

SHEET 1 OF 1

ALL DIMENSIONS SHOWN ARE FOR REFERENCE ONLY.

SCALE N/A

SIZE A	CAGE CODE 3FKR5	DRAWN BY K.GLEBOVA	ITEM NO. FMCN1856	REV A
-----------	--------------------	-----------------------	----------------------	----------

T-Rev.D