

# N-F PANEL MOUNT DOUBLE WIDE MOUNT

SC9237

## SPECIFICATIONS

### ELECTRICAL:

FREQUENCY: 0-12 GHZ  
 IMPEDANCE: 50 OHMS  
 OP. TEMP RANGE: -55°C to +155°C

### MECHANICAL:

MATERIAL BODY: BRASS; ALBALOY PLATING  
 CENTER CONTACT: BeCu  
 CONTACT PLATING: Au PER MIL-G-45204  
 INSULATOR: TEFLON  
 INTERFACE: MIL-STD-348A

ROHS COMPLIANT

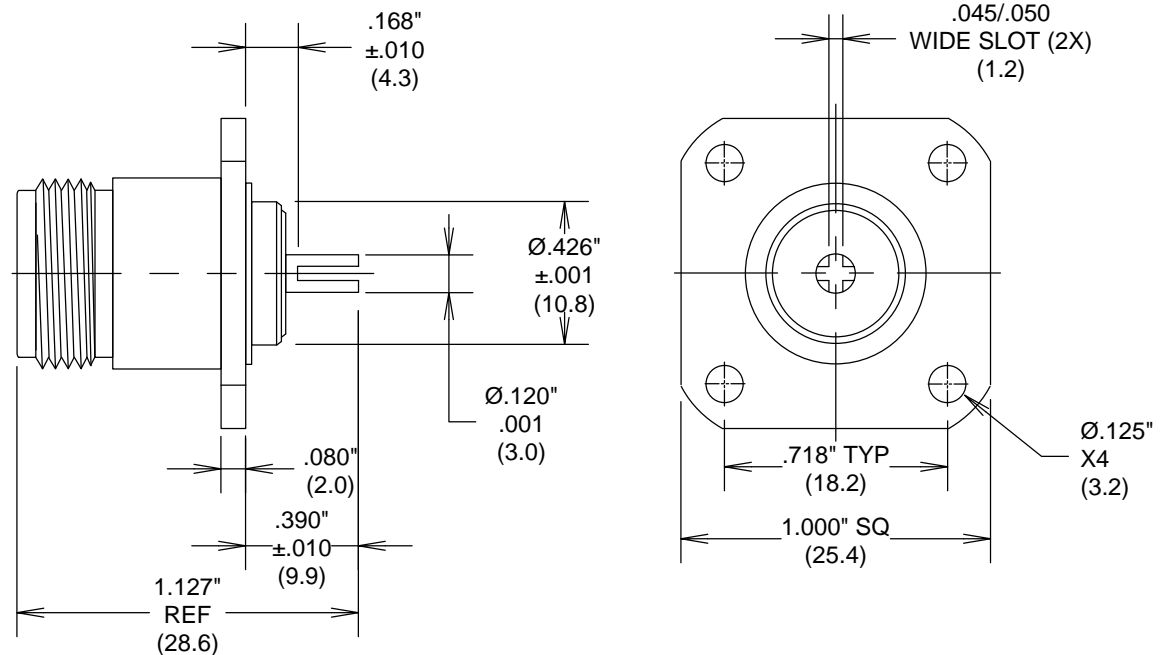

**FAIRVIEW MICROWAVE INC.**

ALLEN, TX 75013 WWW.FAIRVIEWMICROWAVE.COM

TITLE

**N-F PANEL MOUNT  
 DOUBLE WIDE MOUNT**

SIZE	CAGE CODE	DWG NO	REV
<b>A</b>	<b>3FKR5</b>	<b>SC9237</b>	--

ALL DIMENSIONS IN inches(MM) Typical

SCALE	SHEET
-------	-------